

Charge Cart

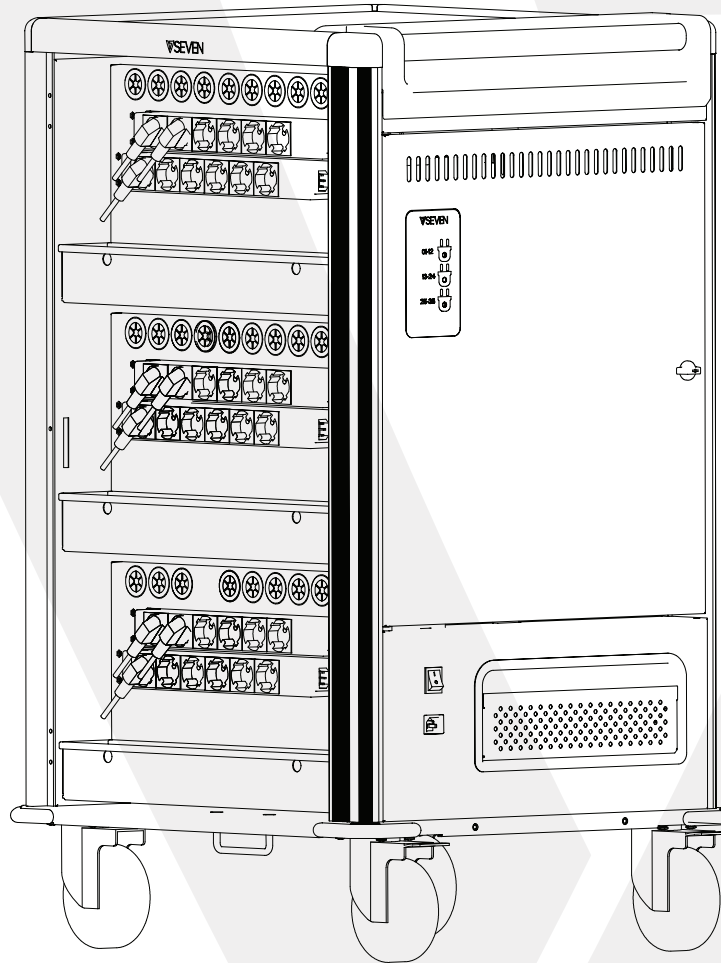

CHGCT30-2E
CHGCT30-2K
CHGCT36-2E

TABLE OF CONTENTS

1 Safety and Warnings

2 Getting Started

Package Includes

Cart Diagram

Unboxing

Locking the Cart

3 Setup

Plugging in Devices

Advanced Features

4 Technical Specs

CAUTION

- To reduce risk of electric shock only use this product indoors.
- This product is heavy. Use caution handling and keep upright. Do not attempt to unpack or move it unassisted.
- Use caution when unpacking and save the packing material for later use. Scratches and other damage caused by mishandling is not covered by the warranty.
- Do not allow anyone to sit, stand, or climb on this product.
- Do not block the ventilation holes used for air circulation.
- Do not overload heavy objects on or inside this product.
- Before moving this product, disconnect the power from the wall outlet.
- While moving this product, make sure the power cord is secured.
- This product should always be used by adults or with adult supervision.
- Never unplug this product from the outlet when hands are wet or by pulling the power cord.
- Do not use an extension cord in conjunction with this product.
- Connection to any other type of receptacle other than a two-pole, three-wire grounded receptacle may result in shock hazard as well as violate local electrical codes.
- In the event of an emergency, disconnect the power cord from the AC power outlet.
- Do not plug the input of this product into its own output.
- Do not attach an additional extension cord, power strip, or surge protector to this product.
- Do not attach non-computer-related items, such as medical equipment, life-support equipment, microwave ovens, or vacuum cleaners to this product.
- Place cables in such a way that they won't be pulled or snagged, and no one can step on or trip over them.
- Do not attempt to disassemble this product. This product contains no user replaceable parts. Only factory service personnel may perform repairs.
- If this product is misused, incorrectly operated or repaired, the warranty will be void.
- Do not remove plugs from outlets in use labeled "Do not remove" with a red sticker. These are required for the charging system and auxiliary outlets of the cart to function.
- **Service Door** - Please open only if requested by V7 Technical Support.

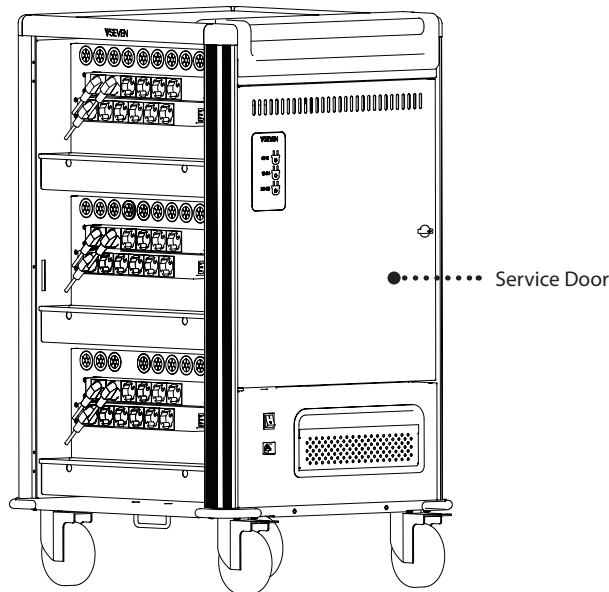

2 GETTING STARTED

Package includes

- AC Power Cord
- 2 Service Door Keys
- 4 Device/Power Supply Door Keys

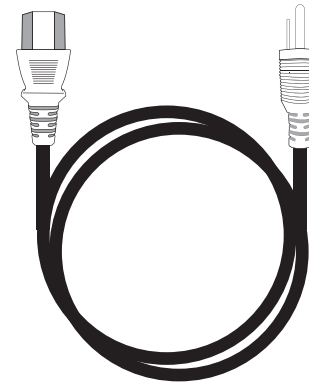
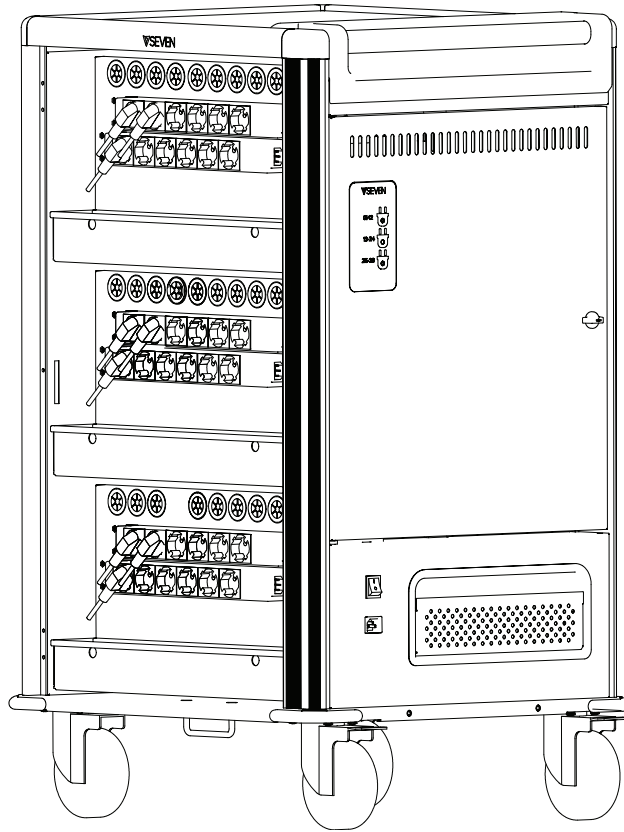

AC Power Cord

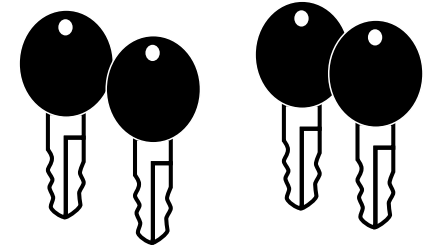

Device/Power Supply
Door Keys

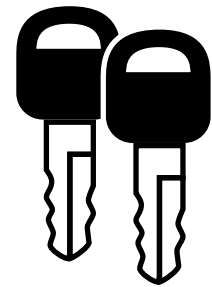

Service Door Keys

Cart Diagram

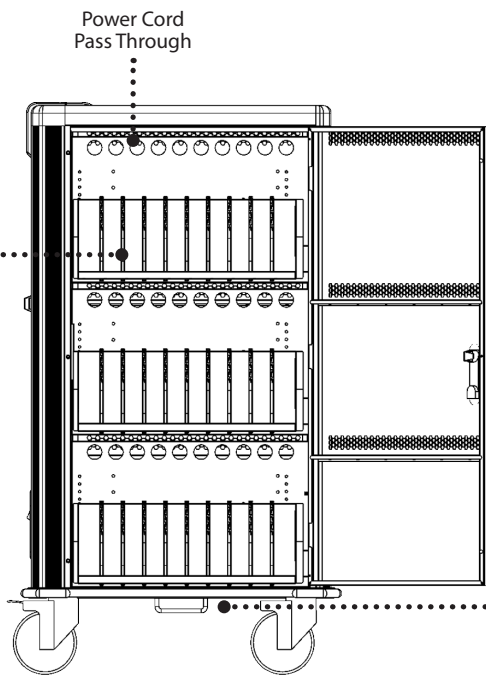
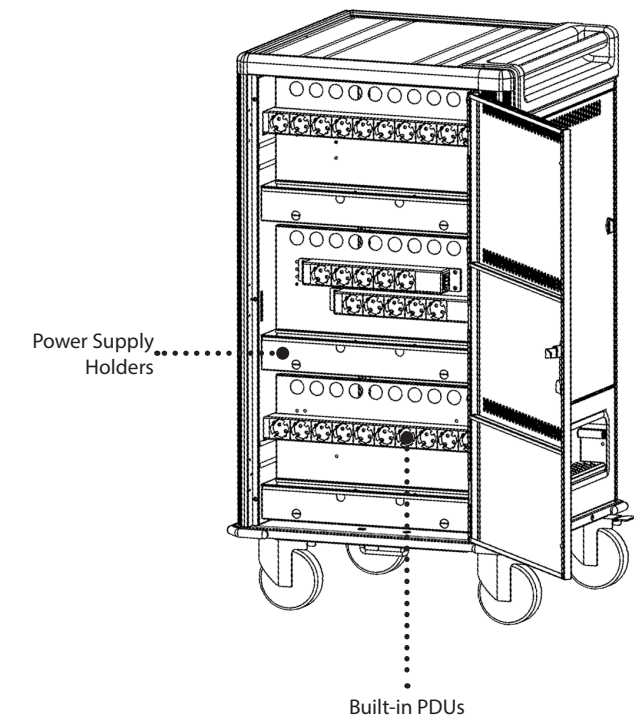
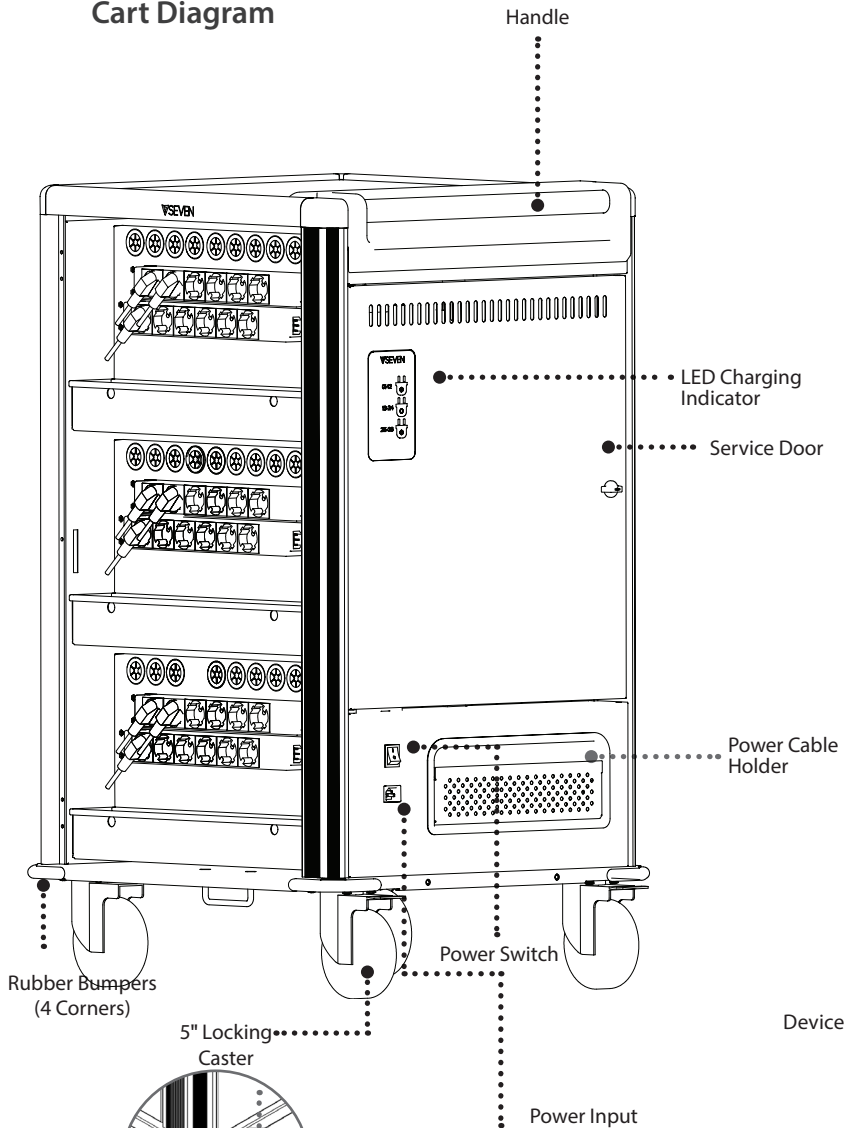

Locking Point
*Security Lock Not included

Remove from pallet

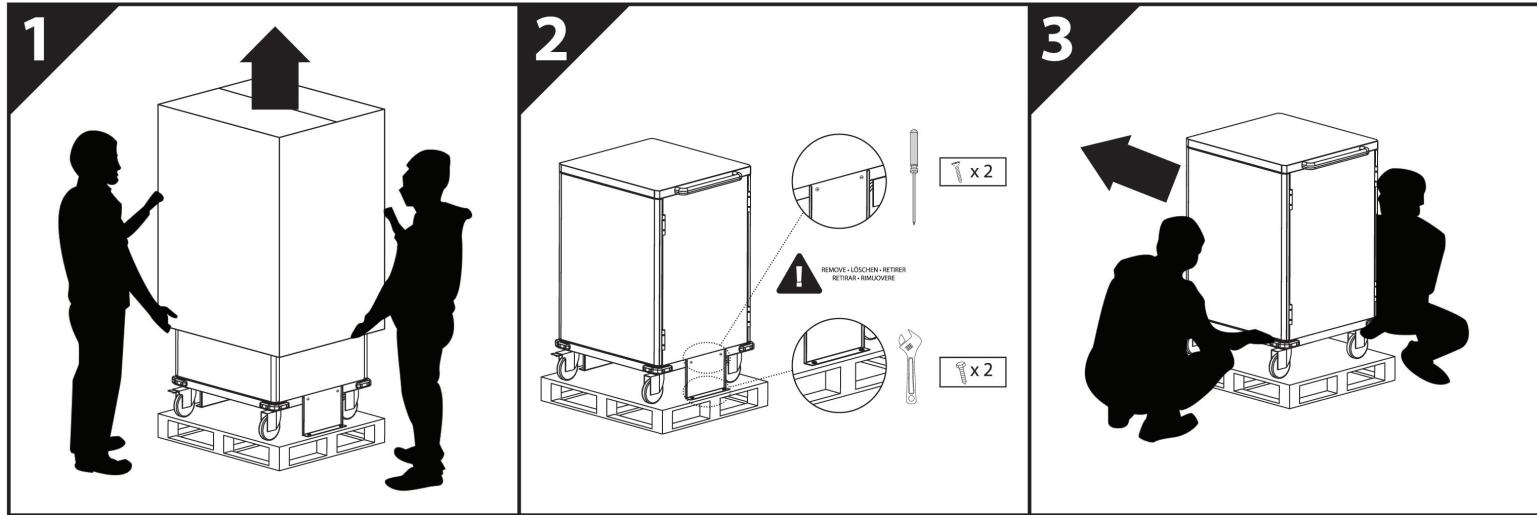

Open Doors
1. Lift Handle

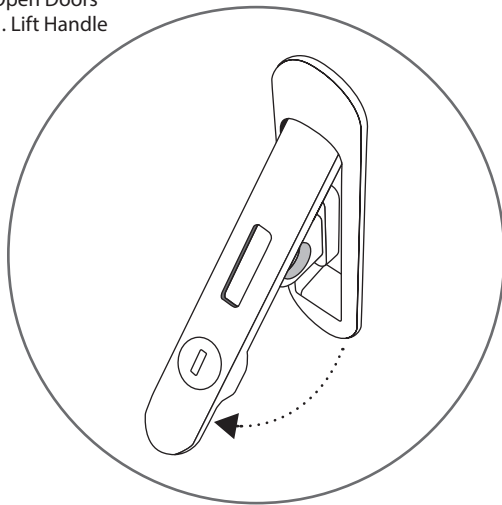

2. Turn left or right
to open

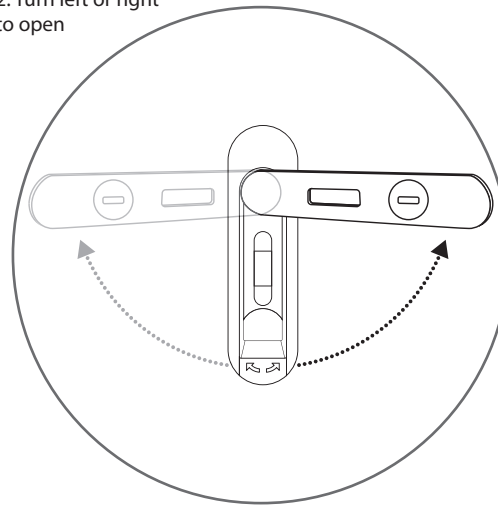

Door Locks

Service Door - Side

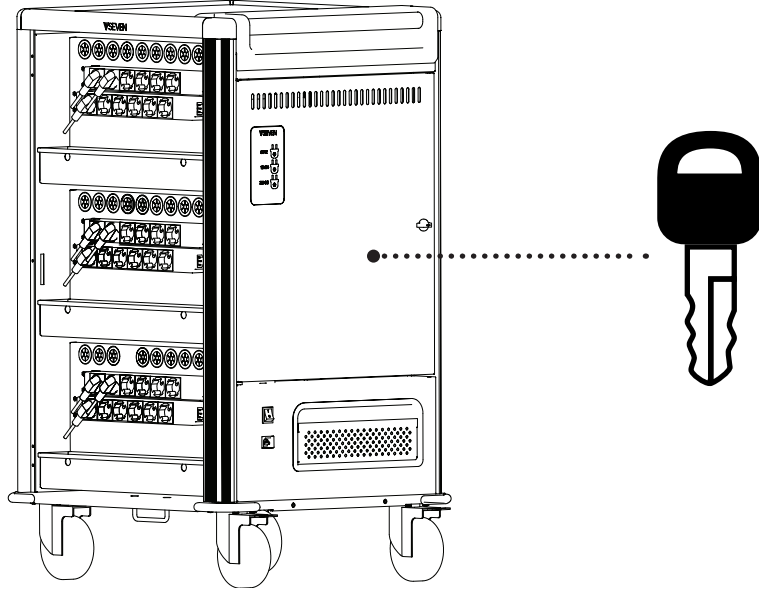

Device/Power Supply Door - Front and Back

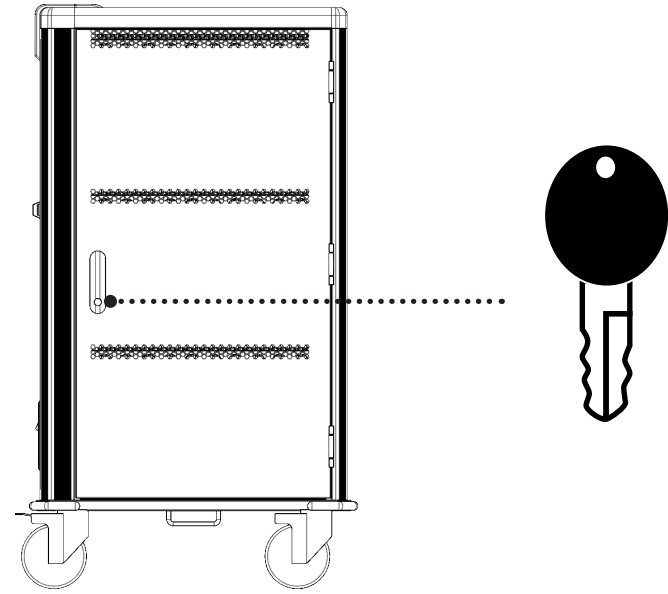

Pad Lock Loop

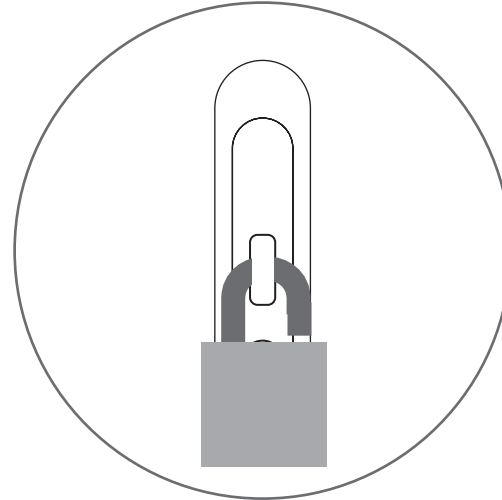
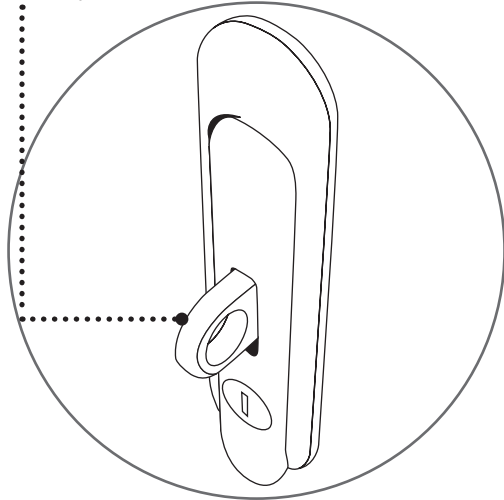

***Pad lock not included**

3 SETUP

1. Plug cart into outlet

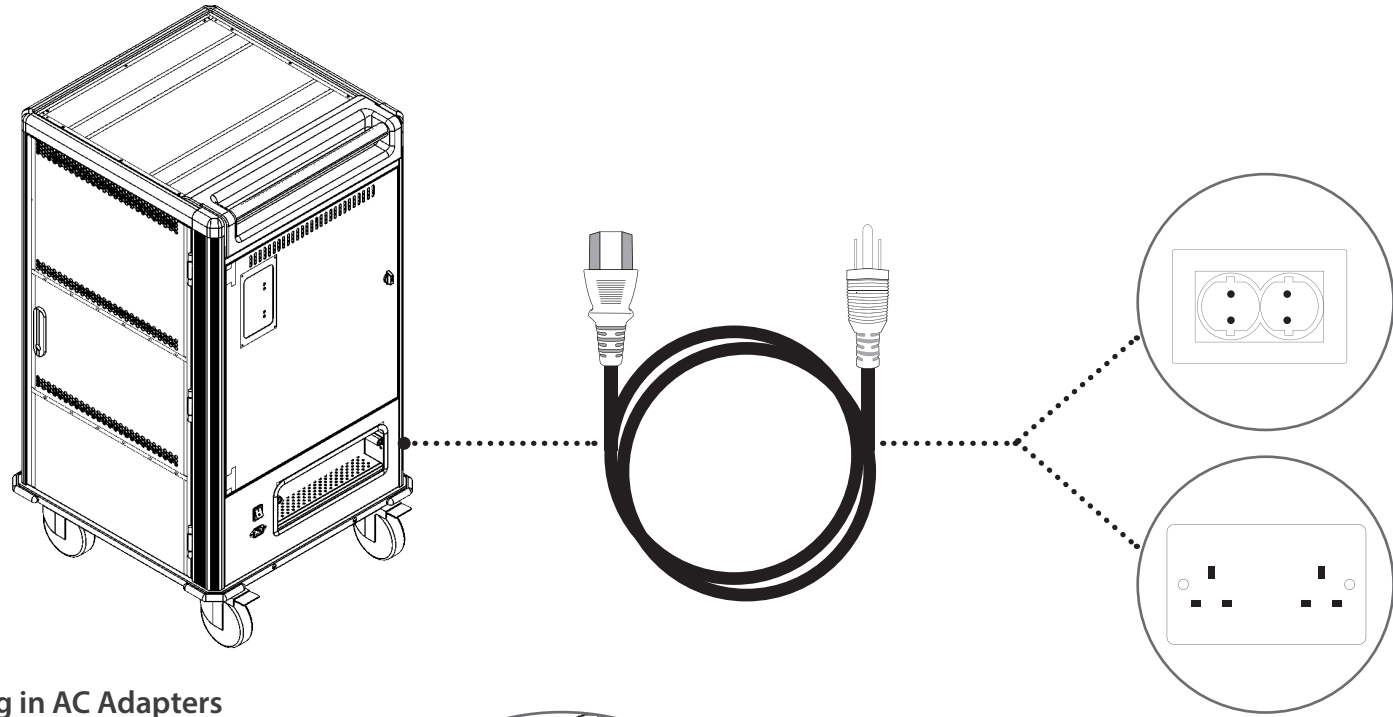

2. Plug in AC Adapters

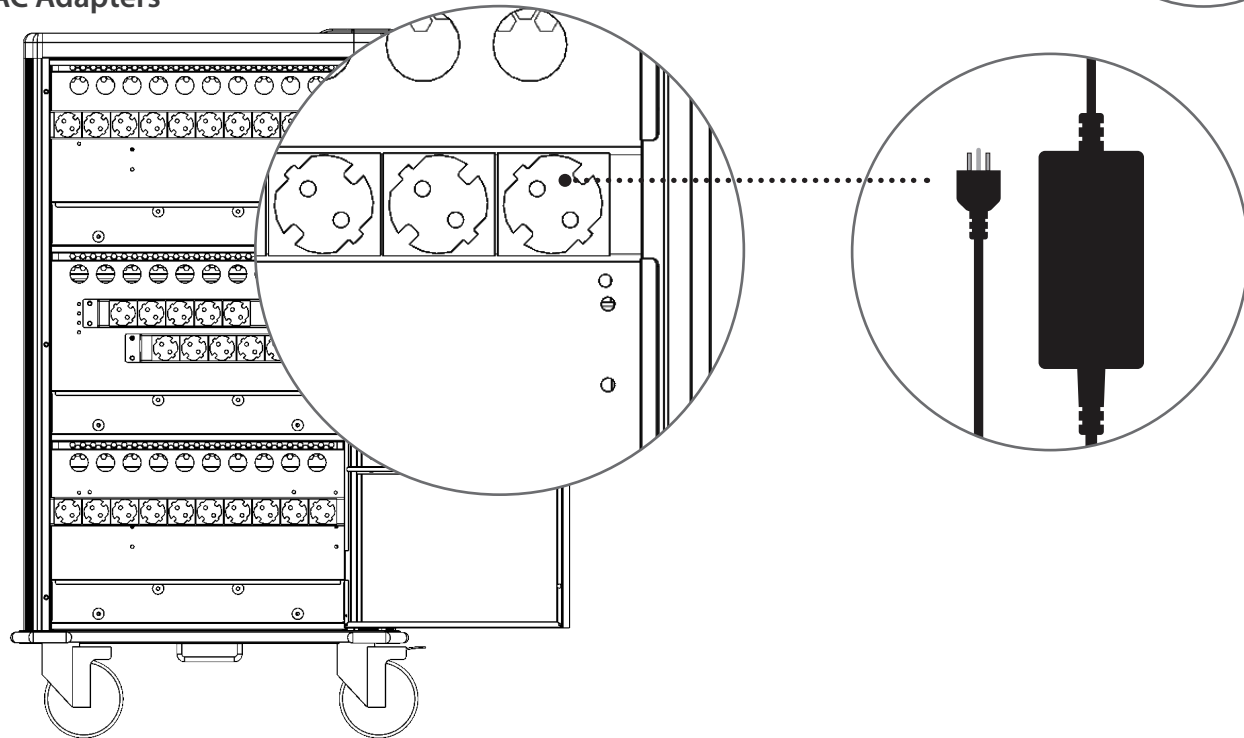

3. Place adapters into power supply holders

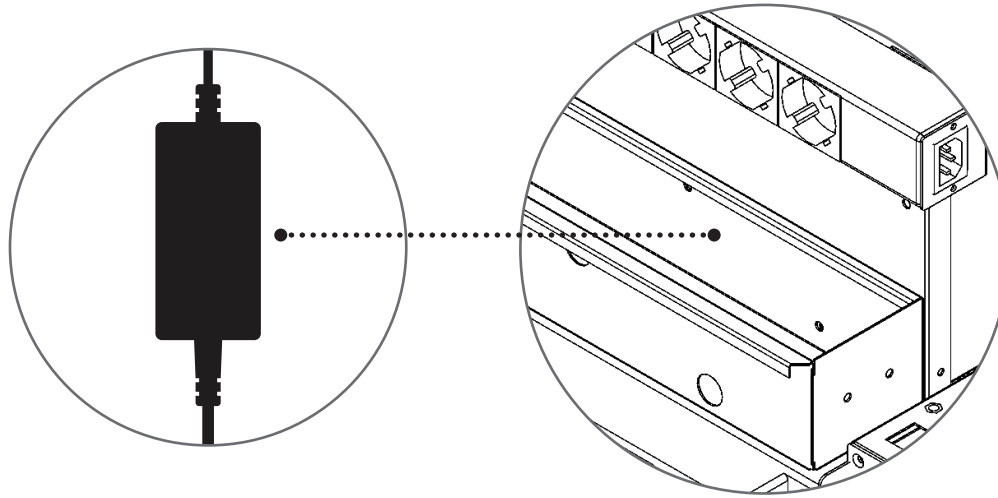

4. Insert the adapters through the pass through holes

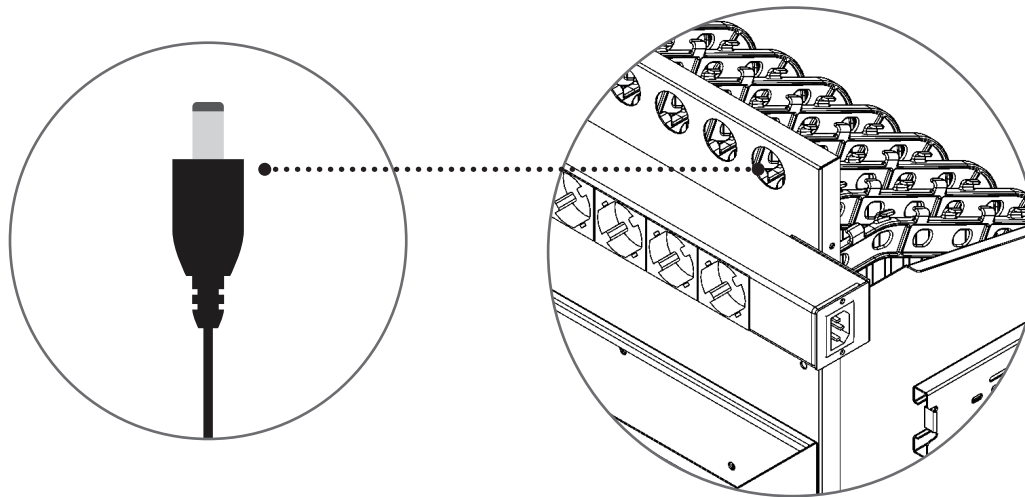

5. Place the adapter wires on the cable holder dividers

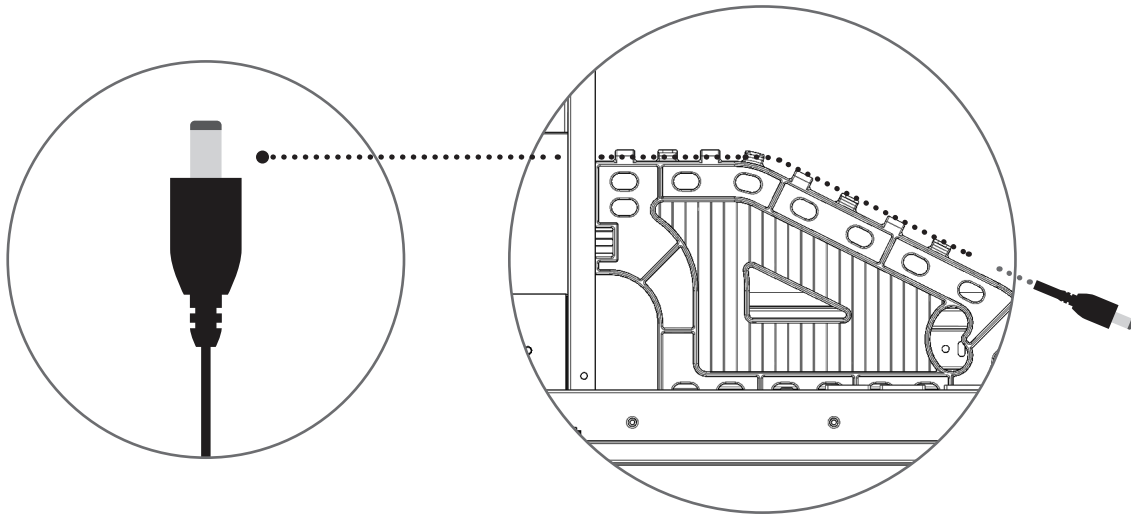

6. Place the devices in the dividers

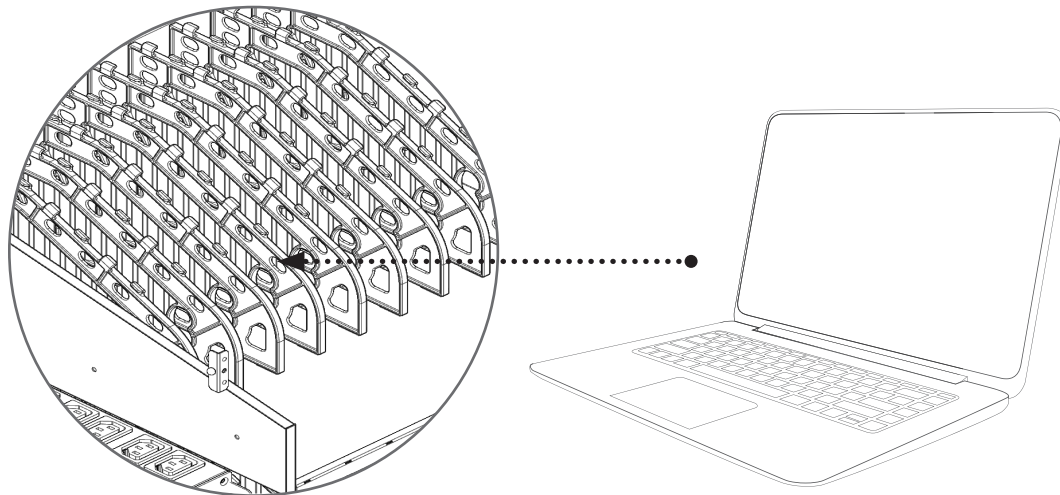

Charging System

Charging all of your devices at one time can overload a typical circuit. V7 Charge Carts are equipped with an intelligent timing device that automatically switches the AC power supply from one half of the device outlets to the other to help protect against overload.

The LED indicator on the outside of the cart will show you which set is currently charging.

Charging System	Bank Sensor Intelligent
How it Charges	Charging alternates 1 row at a time for 10 minutes. When total current is less than 15a, will simultaneously charge more rows.
LED Indicator	Blue (On): Charging Off: Not Charging

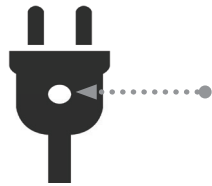

The LED indicator will illuminate Blue when charging

Cart Dimensions

CHGCT30

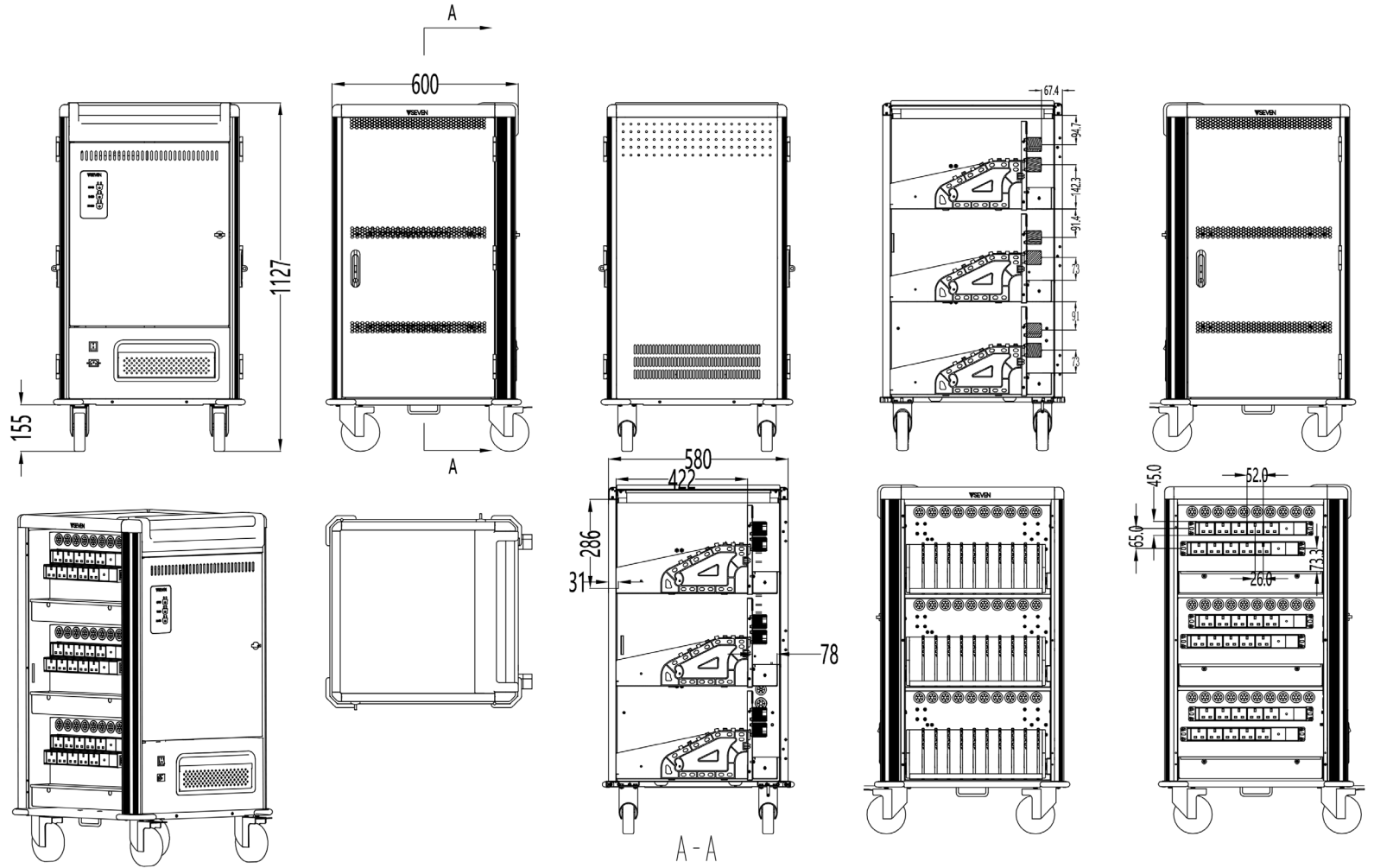

CHGCT36

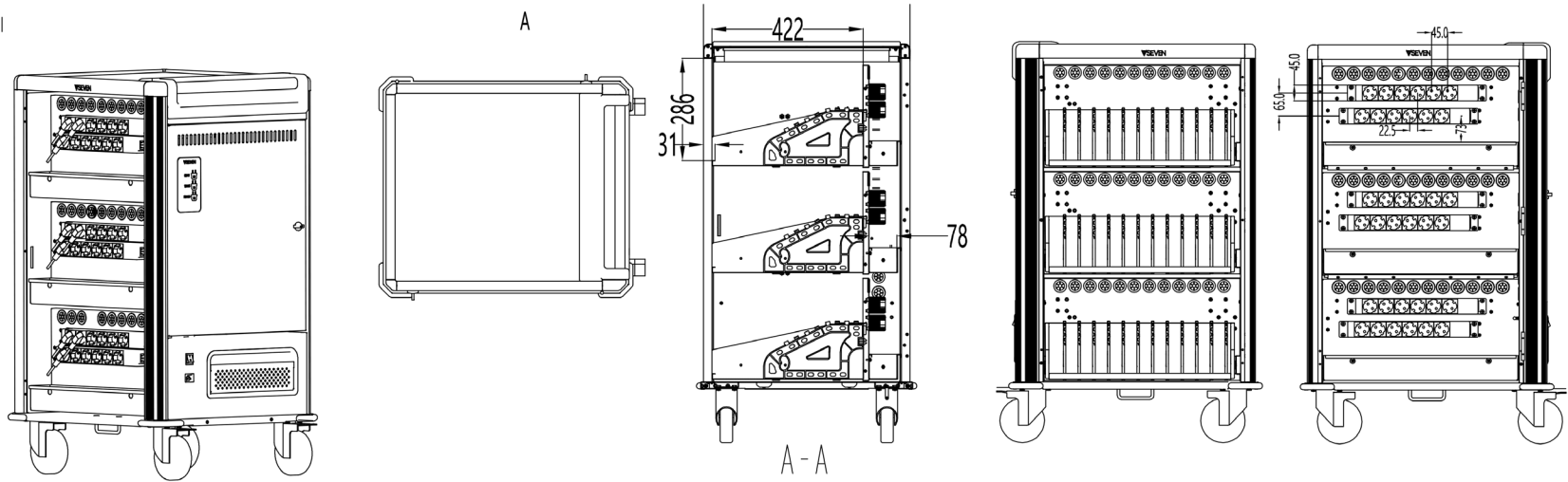
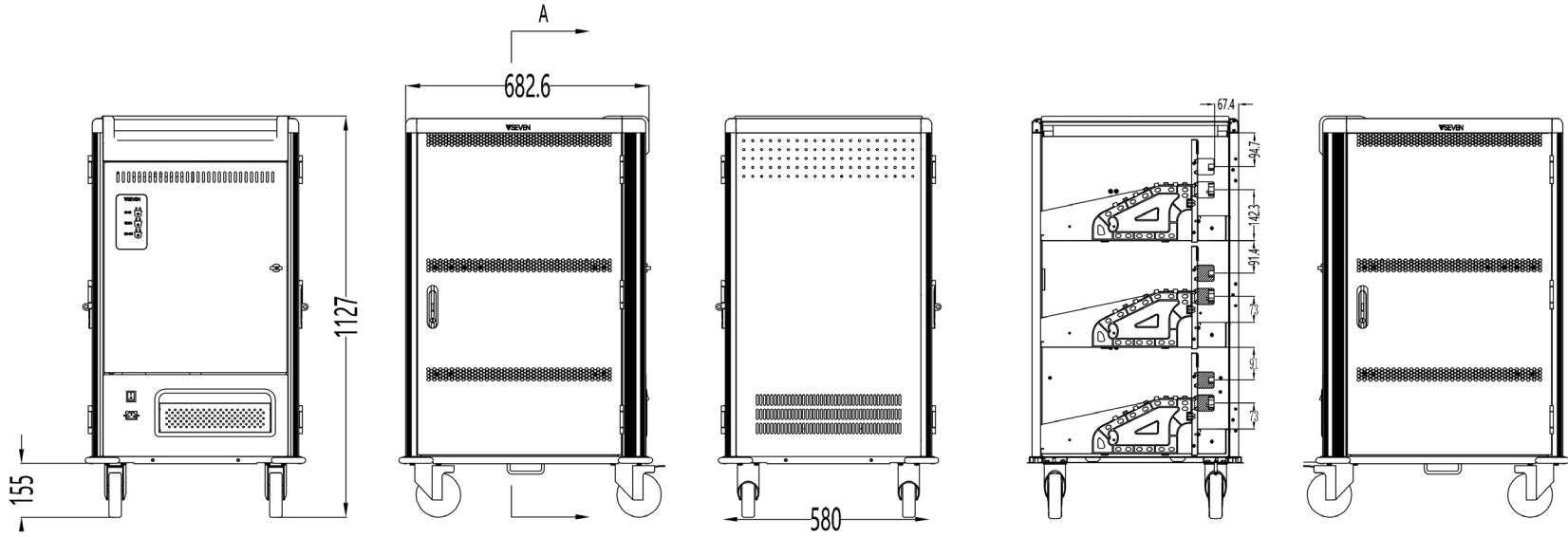

Specifications

	CHGCT30	CHGCT36
Color	Black and Dark Gray	Black and Dark Gray
Material	High-grade 18 gauge cold rolled steel	High-grade 18 gauge cold rolled steel
Numbered Device Spaces	30	36
Organization and convenience	Flexible device dividers with cable channels and numbered device slots, numbered power adapter slots with cable management, recessed push handle	Flexible device dividers with cable channels and numbered device slots, numbered power adapter slots with cable management, recessed push handle
Warranty	5 Year	5 Year
Package Contents	Charging Cart, 6 ft (1.83 m) Power Cord, Manual	Charging Cart, 6 ft (1.83 m) Power Cord, Manual
Input Voltage	230VAC, 15A, 60HZ	230VAC, 15A, 60HZ
Output Voltage	230VAC, 15A, 60HZ	230VAC, 15A, 60HZ
Charging System	Intelligent Charging	Intelligent Charging
Rolling Casters size	5 in (12.7 cm)	5 in (12.7 cm)
Product Dimensions	23.62 x 22.82 x 44.37 in (599.94 x 579.62 x 1126.998 mm)	26.89 x 22.83 x 44.47 in (683 x 580 x 1127 mm)
Product Weight	171.96 lbs (78 kg)	187.39 lbs (85 kg)
Package Size	25.98 25.59 x 50.08 in ()	28.94 x 25.59 x 50.08 in (753 x 650 x 1272 mm)
Package Weight	205.03 lbs (93 kg)	218.26 lbs (99 kg)
Device slot dimensions	16.61 x 1.38 x 11.25 in (422 x 35 x 286 mm)	16.61 x 1.38 x 11.25 in (422 x 35 x 286 mm)
Power adapter slot dimensions	3.07x 18.22 x 4.48 in (78 x 463 x 114mm)	3.07x 18.22 x 4.48 in (78 x 463 x 114mm)
Environment*	"Operating: -10°C to 40°C Humidity: 20% to 80% RH Storage: -40°C to +60°C Humidity: 20% to 90% RH"	"Operating: -10°C to 40°C Humidity: 20% to 80% RH Storage: -40°C to +60°C Humidity: 20% to 90% RH"

*Note: For this charge cart only. Check the environment specifications of the devices you are storing.

Ladewagen

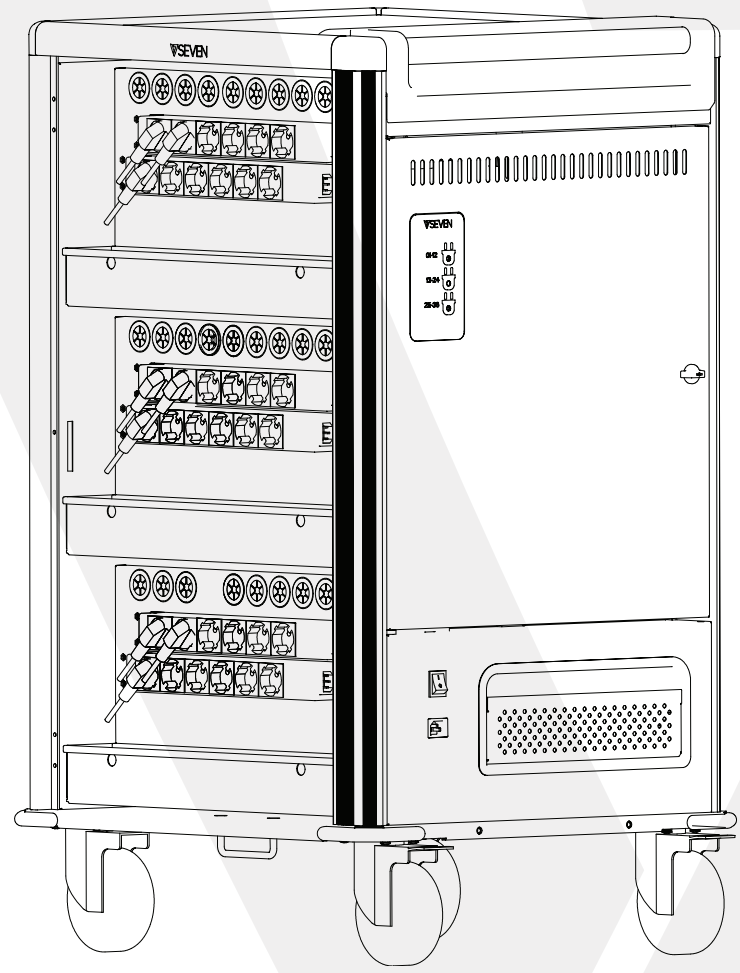

CHGCT30-2E
CHGCT30-2K
CHGCT36-2E

1 Sicherheits- und Warnhinweise

2 Erste Schritte

Packungsinhalt

Übersicht

Auspacken

Abschließen des Wagens

3 Einrichtung

Anschließen von Geräten

Erweiterte Funktionen

4 Technische Daten

VORSICHT

- Verwenden Sie zur Verringerung des Stromschlagrisikos dieses Produkt nur in Innenräumen.
- Dieses Produkt ist schwer. Gehen Sie beim Transport vorsichtig vor und halten Sie das Produkt aufrecht. Versuchen Sie nicht, das Produkt ohne Hilfe auszupacken oder zu bewegen.
- Seien Sie beim Auspacken vorsichtig und bewahren Sie das Verpackungsmaterial für den späteren Gebrauch auf. Kratzer und andere Schäden, die durch unsachgemäße Behandlung entstehen, fallen nicht unter die Garantie.
- Lassen Sie niemanden auf diesem Produkt sitzen, stehen oder darauf klettern.
- Blockieren Sie nicht die Belüftungsöffnungen zur Luftzirkulation.
- Überlasten Sie das Produkt nicht mit schweren Gegenständen auf oder in dem Produkt.
- Trennen Sie vor dem Transport dieses Geräts den Stromanschluss von der Steckdose.
- Vergewissern Sie sich beim Transport dieses Produkts, dass das Netzkabel gesichert ist.
- Dieses Produkt sollte immer von Erwachsenen oder unter Aufsicht von Erwachsenen verwendet werden.
- Trennen Sie niemals den Netzstecker von der Steckdose, wenn die Hände nass sind oder indem Sie am Netzkabel ziehen.
- Verwenden Sie kein Verlängerungskabel in Verbindung mit diesem Produkt.
- Der Anschluss an eine andere Art von Steckdose als eine zweipolige, dreidrigige geerdete Steckdose kann zu Stromschlaggefahr führen und die örtlichen elektrischen Vorschriften verletzen.
- Trennen Sie im Notfall das Netzkabel von der Steckdose.
- Schließen Sie den Eingang dieses Produkts nicht an seinem eigenen Ausgang an.
- Schließen Sie kein zusätzliches Verlängerungskabel, Netzteil oder Überspannungsschutzgerät an dieses Produkt an.
- Schließen Sie keine nicht computerbezogenen Gegenstände wie medizinische Geräte, Lebenserhaltungsgeräte, Mikrowellen oder Staubsauger an dieses Produkt an.
- Verlegen Sie die Kabel so, dass sie nicht gespannt oder geknickt werden und niemand darauf treten oder darüber stolpern kann.
- Versuchen Sie nicht, das Gerät zu zerlegen. Dieses Produkt enthält keine von Benutzern austauschbaren Teile. Reparaturen dürfen nur vom Werks-Servicepersonal durchgeführt werden.
- Wird dieses Produkt manipuliert, falsch bedient oder repariert, erlischt die Garantie.
- Entfernen Sie keine Stecker aus den Steckdosen, die mit der Aufschrift „Nicht entfernen“ auf einem roten Aufkleber gekennzeichnet sind. Diese werden benötigt, damit das Ladesystem und die Zusatzsteckdosen des Wagens funktionieren.
- **Wartungszugang** – Bitte nur öffnen, wenn Sie dazu vom Technischen Support von V7 aufgefordert werden.

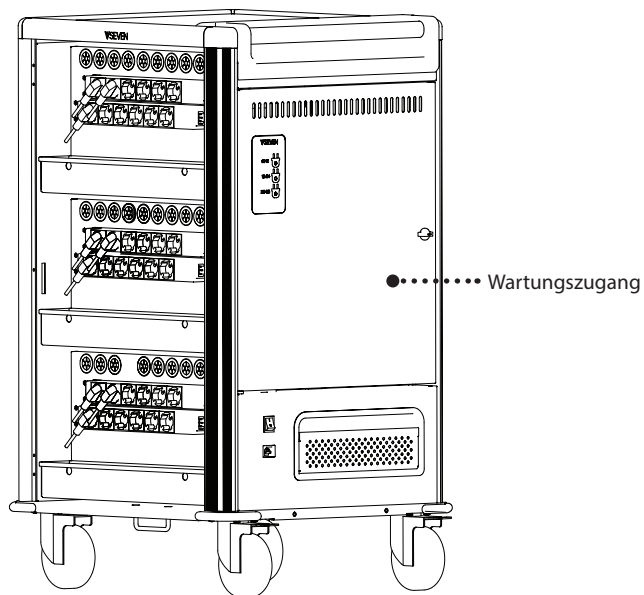

Packungsinhalt

- AC-Netzkabel
- 2 Service-Tür-Schlüssel
- 4 Geräte-/Stromversorgungstürschlüssel

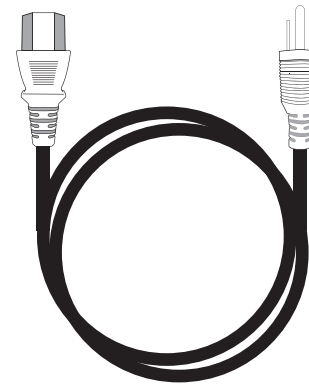
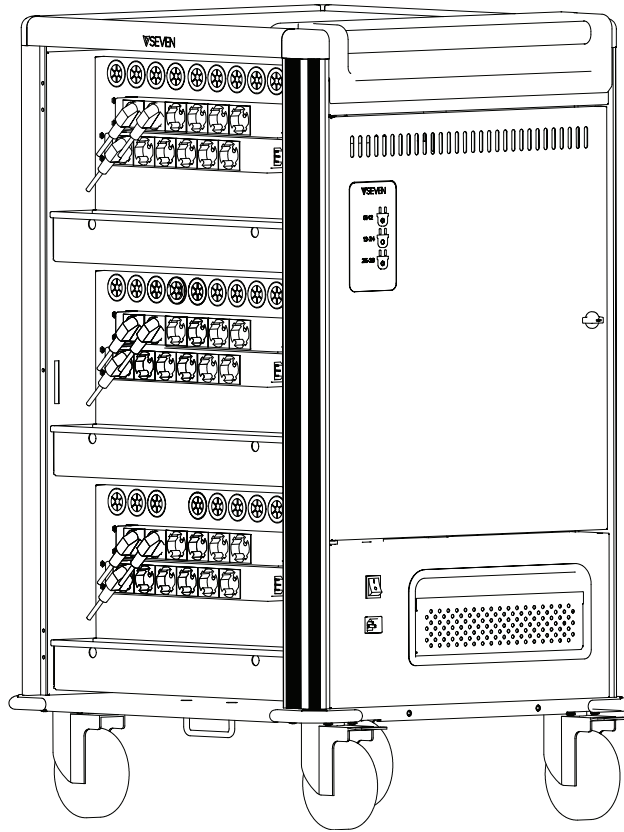

AC-Netzkabel

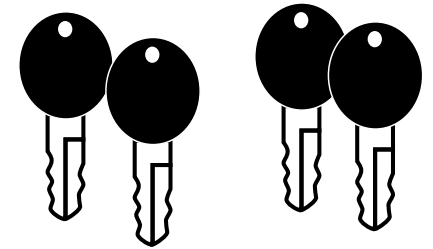

Gerät/Stromversorgung
Türschlüssel

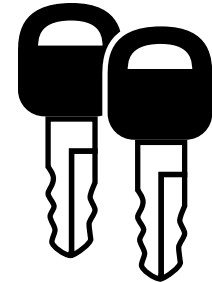

Service-Tür-Schlüssel

Von Palette entfernen

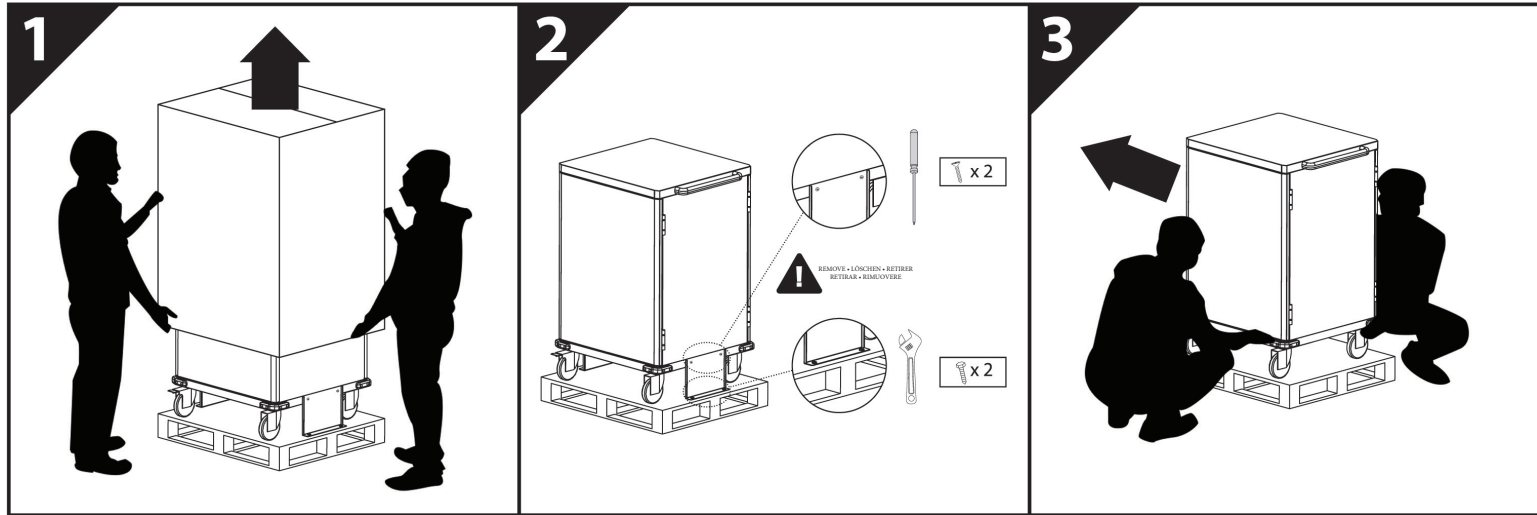

Türen öffnen
1. Griff anheben

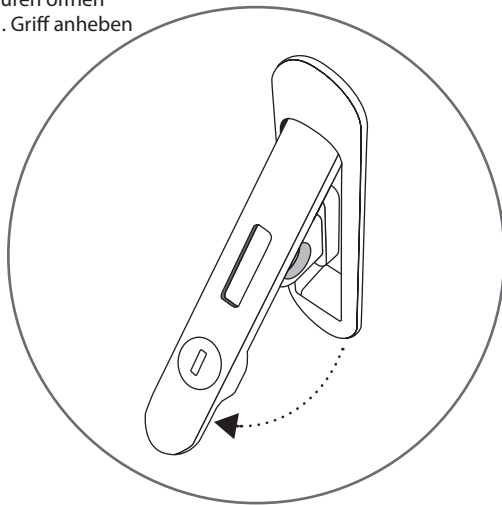

2. Zum Öffnen nach links
oder rechts drehen

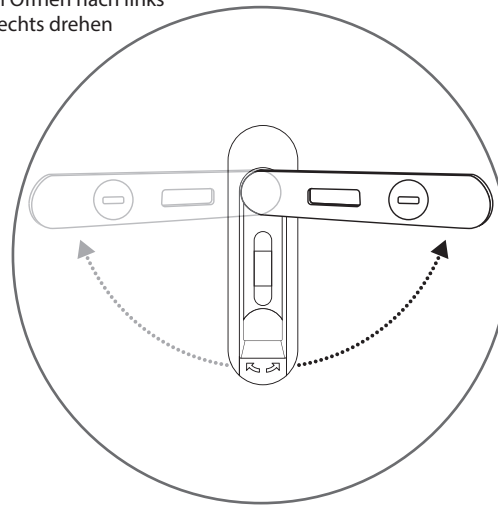

Türschlösser

Servicetür - Seite

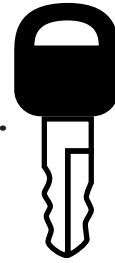
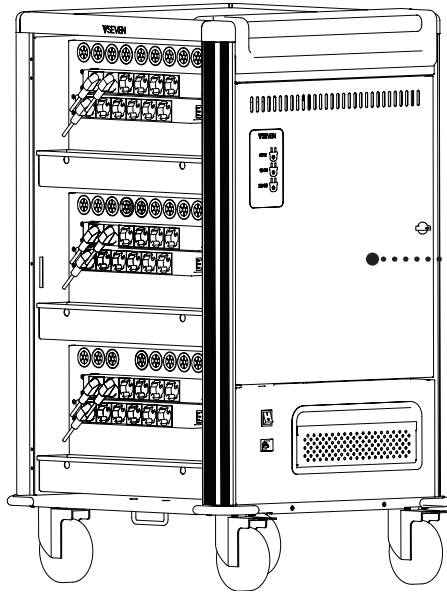

Geräte-/Stromversorgungstür - Vorder- und Rückseite

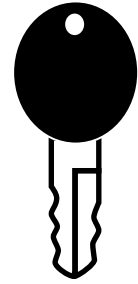
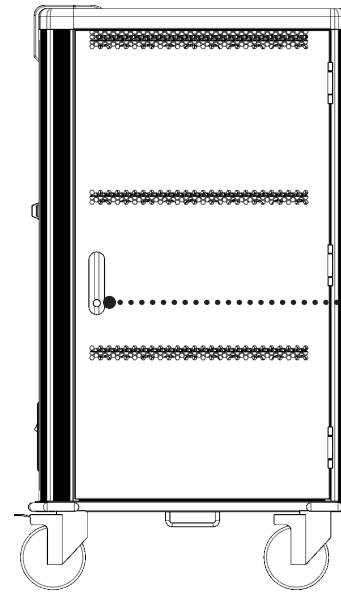

Verriegelungslasche

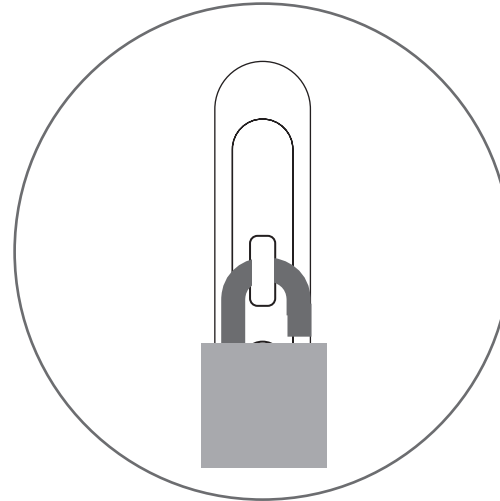
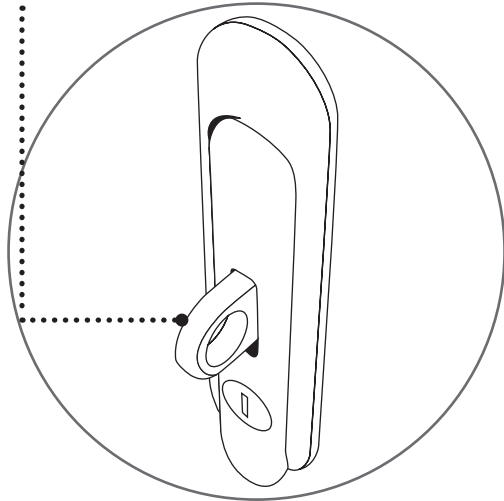

*** Vorhängeschloss nicht enthalten**

1. Wagen mit Stromanschluss verbinden

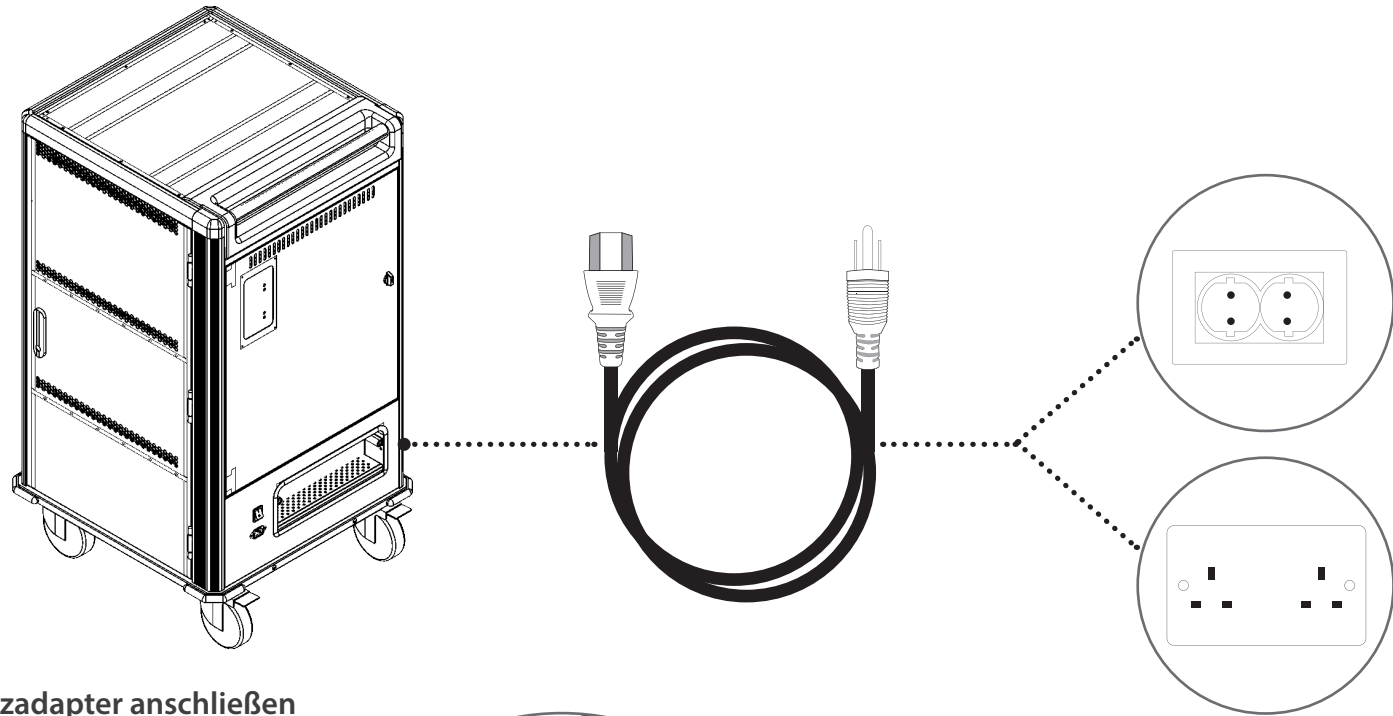

2. Netzadapter anschließen

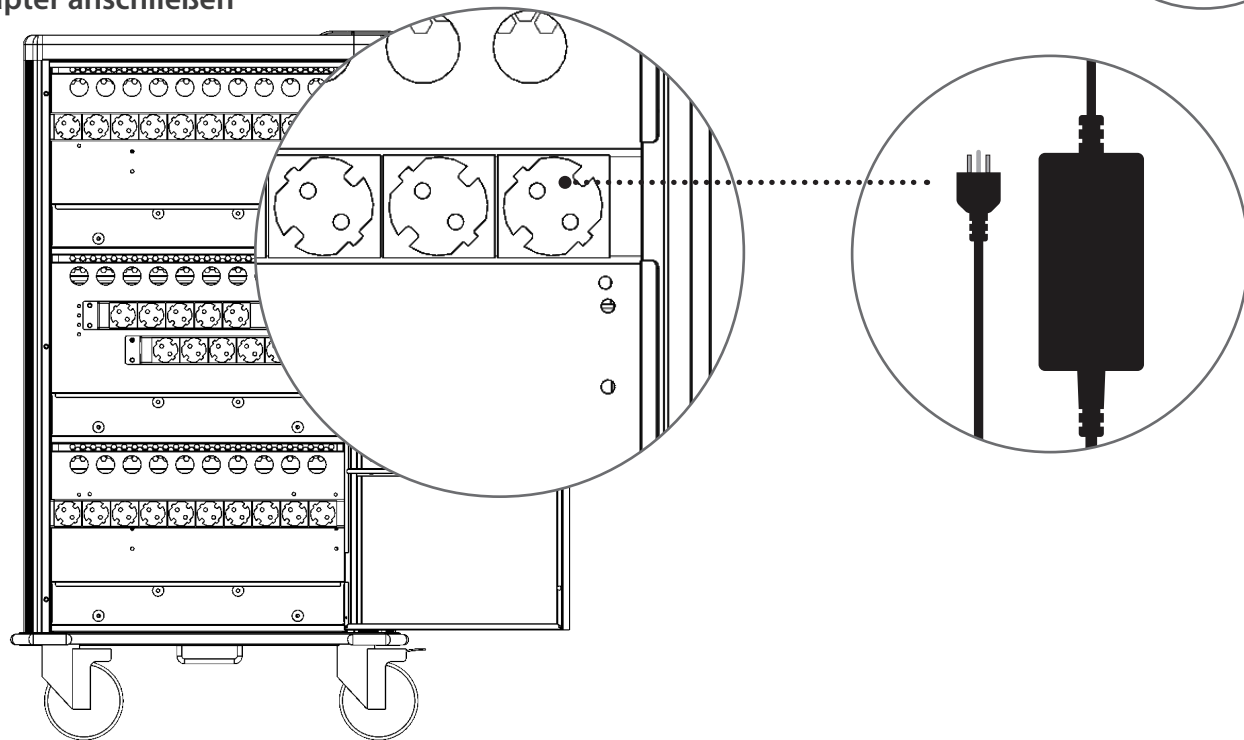

3. Adapter in die Netzteilhalterungen einschieben

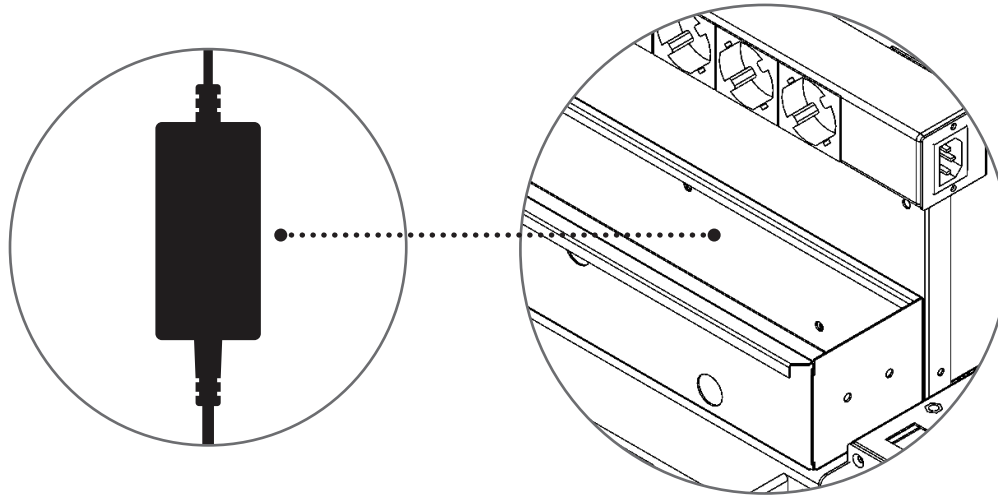

4. Adapter durch die Durchlassöffnungen führen

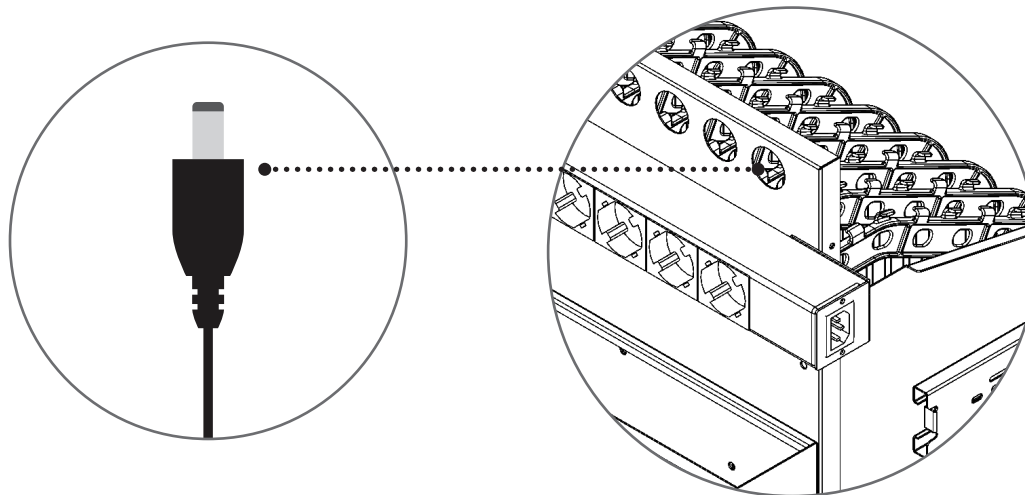

5. Die Adapterkabel an den Kabeltrennhalterungen befestigen

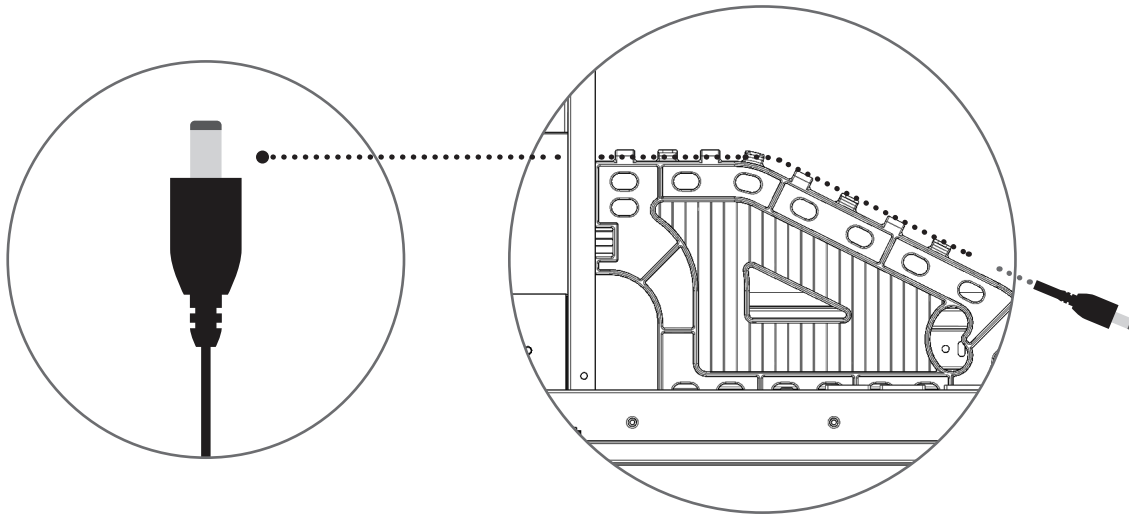

6. Die Geräte auf die Trenner legen

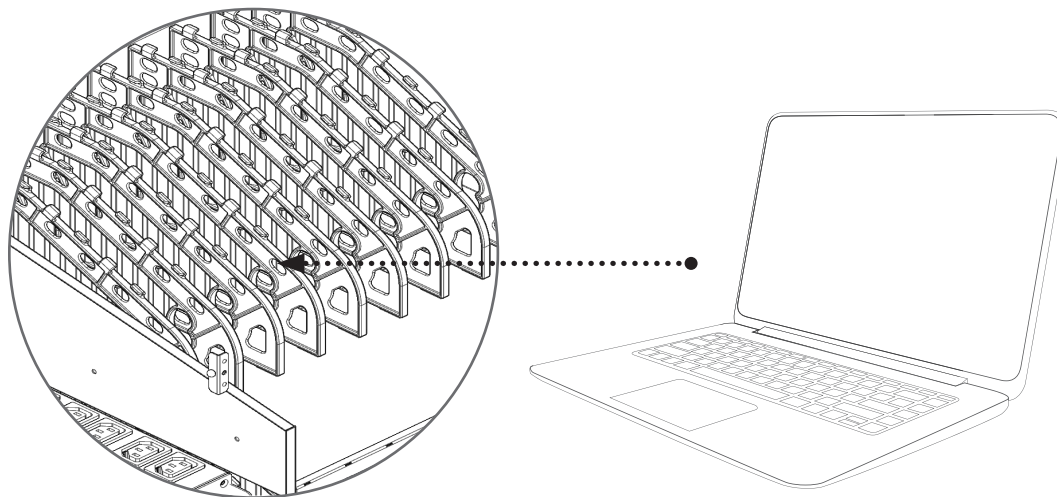

Ladesystem

Wenn Sie alle Ihre Geräte gleichzeitig aufladen, kann ein normaler Stromkreis überlastet werden. Die V7-Ladewagen sind mit einem intelligenten Zeitgeber ausgestattet, der die Stromversorgung automatisch von einer Hälfte der Geräteanschlüsse auf die andere umschaltet, um eine Überlastung zu vermeiden.

Die LED-Anzeige an der Außenseite des Wagens zeigt Ihnen an, welches Gerät gerade aufgeladen wird.

Ladesystem	Intelligenter Ladesensor
Ladefunktion	Abwechselndes Laden in 2 Gruppen. Wenn der Gesamtstrom unter 14 A fällt, werden alle Geräte geladen
LED-Anzeige	Blau (ein): Ladevorgang Aus: Kein Ladevorgang



Die LED-Anzeige leuchtet beim Laden blau.

CHGCT30

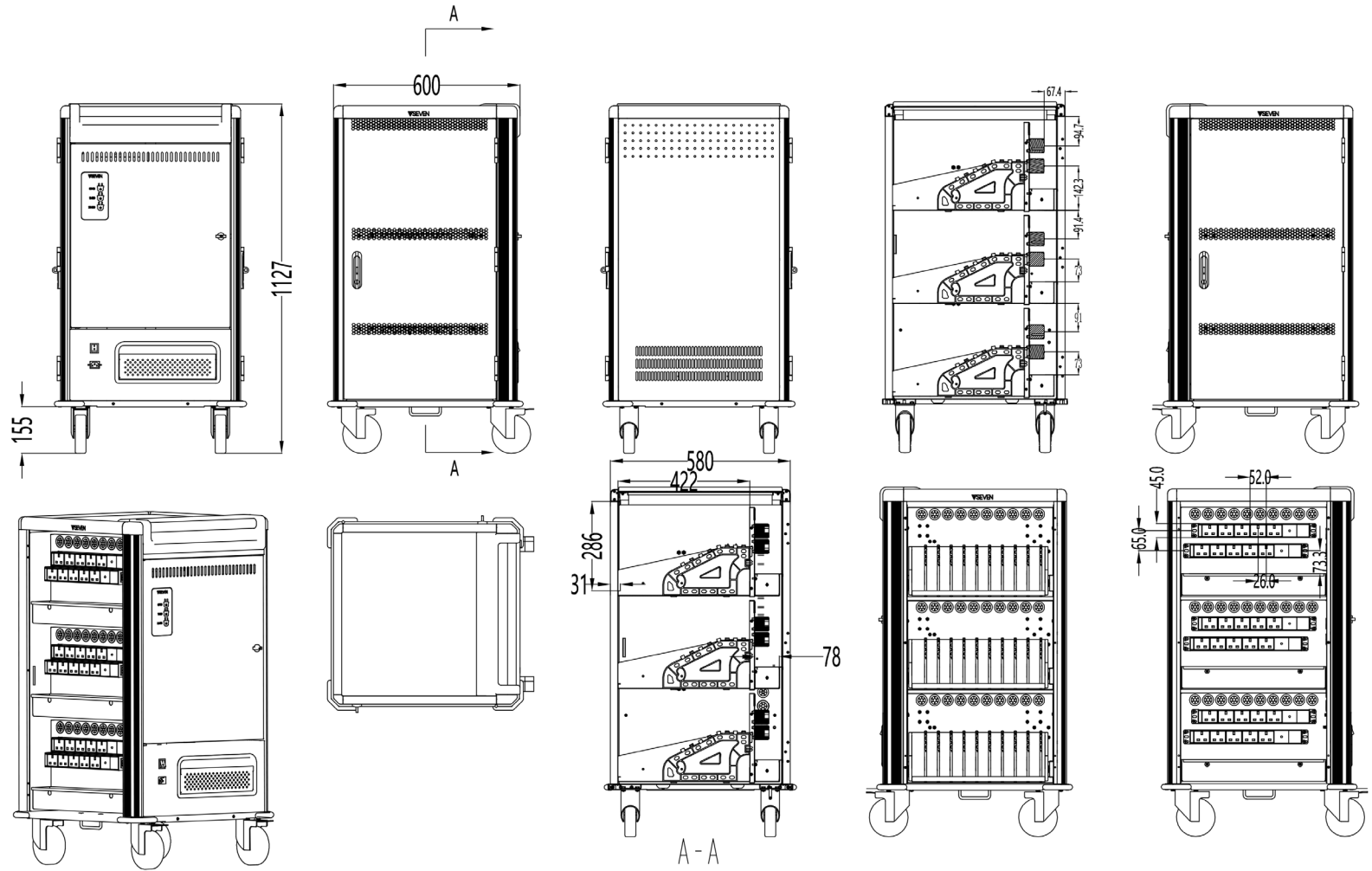

CHGCT36

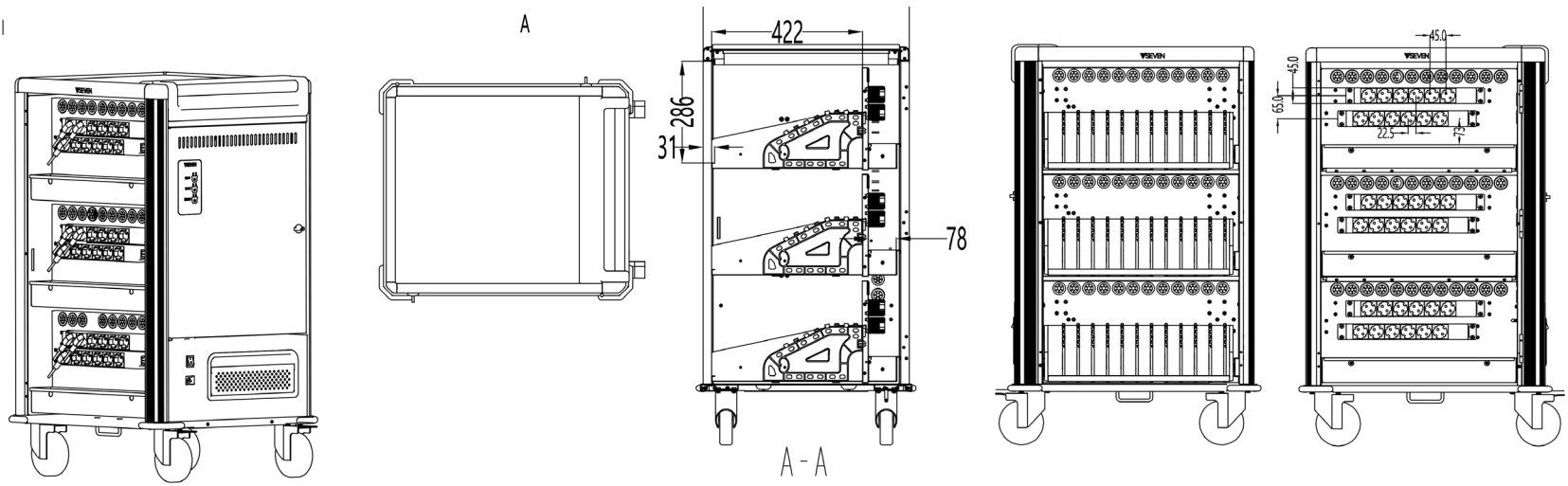
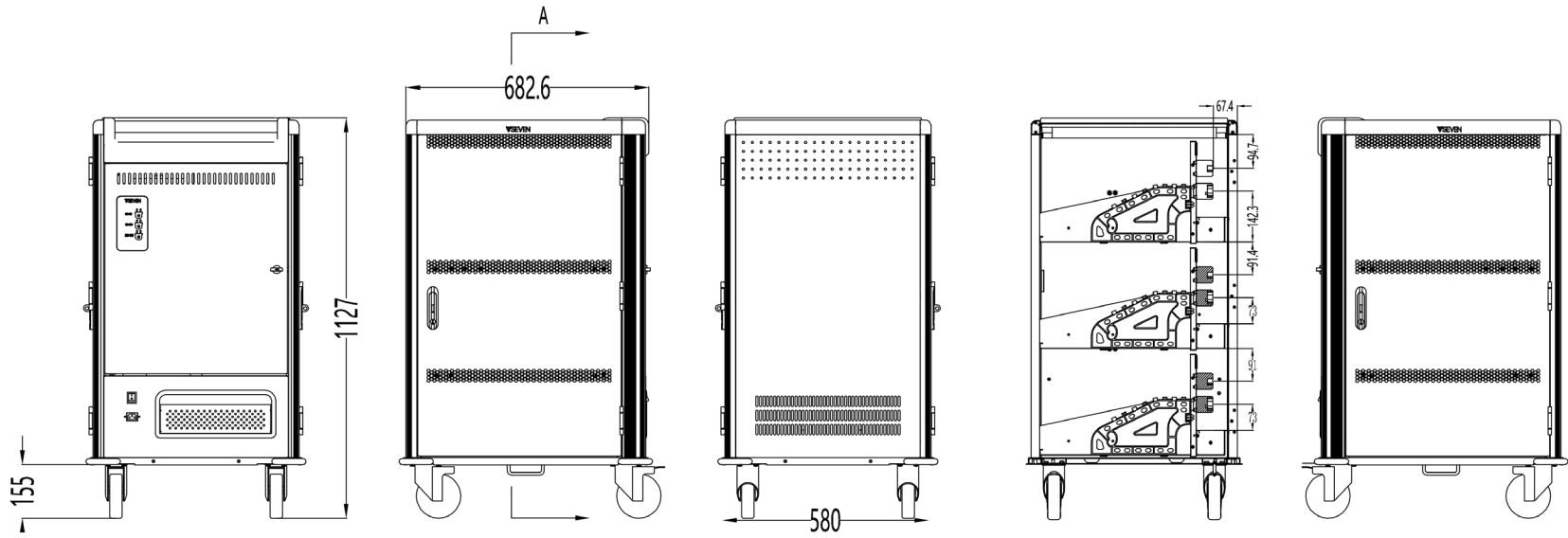

	CHGCT30	CHGCT36
Farbe	Schwarz und dunkelgrau	Schwarz und dunkelgrau
Material	Hochwertiger, kaltgewalzter Stahl, Stärke 18	Hochwertiger, kaltgewalzter Stahl, Stärke 18
Nummerierte Geräteplätze	30	36
Organisation und Komfort	Flexible Gerätetrenner mit Kabelkanälen und nummerierten Gerätefächern, nummerierte Netzteilfächer mit Kabelmanagement, versenkter Schiebegriff	Flexible Gerätetrenner mit Kabelkanälen und nummerierten Gerätefächern, nummerierte Netzteilfächer mit Kabelmanagement, versenkter Schiebegriff
Garantie	5 Jahre	5 Jahre
Verpackungsinhalt	Ladewagen, 1,83 m Netzkabel, Handbuch	Ladewagen, 1,83 m Netzkabel, Handbuch
Eingangsspannung	230 VAC, 15 A, 60 Hz	230 VAC, 15 A, 60 Hz
Ausgangsspannung	230 VAC, 15 A, 60 Hz	230 VAC, 15 A, 60 Hz
Ladesystem	Intelligente Ladefunktion	Intelligente Ladefunktion
Größe der Lenkrollen	12,7 cm	12,7 cm
Abmessungen (Produkt)	23.62 x 22.82 x 44.37 in (599.94 x 579.62 x 1126.998 mm)	26.89 x 22.83 x 44.47 in (683 x 580 x 1127 mm)
Produktgewicht	171.96 lbs (78 kg)	187.39 lbs (85 kg)
Verpackungsgröße	25.98 x 25.59 x 50.08 in ()	28.94 x 25.59 x 50.08 in (753 x 650 x 1272 mm)
Verpackungsgewicht	205.03 lbs (93 kg)	218.26 lbs (99 kg)
Abmessungen der Gerätefächer	16.61 x 1.38 x 11.25 in (422 x 35 x 286 mm)	16.61 x 1.38 x 11.25 in (422 x 35 x 286 mm)
Abmessungen der Steckplätze für das Netzteil	3.07x 18.22 x 4.48 in (78 x 463 x 114mm)	3.07x 18.22 x 4.48 in (78 x 463 x 114mm)
Umgebung*	„Betrieb: -10 °C bis 40 °C Luftfeuchtigkeit: 20 % bis 80 % rel. Feuchte Lagerung: -40 °C bis 60 °C Luftfeuchtigkeit: 20 % bis 90 % rel. Feuchte“	„Betrieb: -10 °C bis 40 °C Luftfeuchtigkeit: 20 % bis 80 % rel. Feuchte Lagerung: -40 °C bis 60 °C Luftfeuchtigkeit: 20 % bis 90 % rel. Feuchte“

* Hinweis: Nur für diesen Ladewagen. Prüfen Sie die Umgebungsspezifikationen der zu lagernden Geräte.

Armario de carga

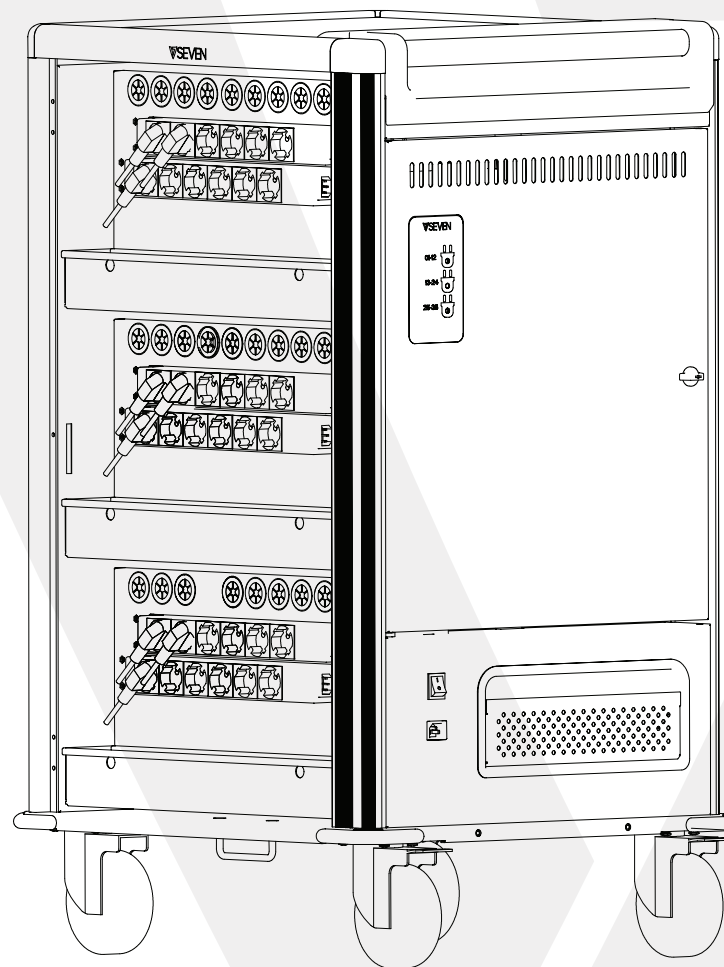

CHGCT30-2E
CHGCT30-2K
CHGCT36-2E

1 Seguridad y advertencias

2 Inicio

Contenido del paquete

Diagrama del armario

Desempaquetado

Bloqueo del armario

3 Configuración

Conectar los dispositivos

Funciones avanzadas

4 Especificaciones técnicas

PRECAUCIÓN

- Para reducir el riesgo de descargas eléctricas, use este producto solamente en interiores.
- Este producto es pesado. Tenga cuidado al manipularlo y manténgalo en posición vertical. No intente desempaquetarlo o moverlo sin ayuda.
- Tenga cuidado cuando lo desempaquete y guarde el material de empaquetado para su posterior utilización. Los arañazos y otros daños causados por una mala gestión no están cubiertos por la garantía.
- No permita que alguien se siente, se suba o se ponga de pie en este producto.
- No bloquee los agujeros de ventilación destinados a la circulación del aire.
- No sobrecargue este producto con objetos pesados, tanto en la parte superior como en la interior.
- Antes de mover este producto, desenchufe el cable de la toma eléctrica.
- Cuando mueva este producto, confirme que el cable de alimentación está asegurado.
- Este producto solo debe ser usado por adultos o bajo su supervisión.
- No desconecte en ningún momento este producto de la toma con las manos mojadas o tirando del cable de alimentación.
- No use un alargador con este producto.
- La conexión de cualquier tipo de toma que no sea de dos polos o de tres clavijas de tierra puede resultar en riesgo de descarga, además de también infringir los códigos locales de electricidad.
- En el caso de una emergencia, desconecte el cable de alimentación de la toma de alimentación de corriente alterna (CA).
- No enchufe la entrada de este producto en su propia salida.
- No conecte un alargador, regleta o protector contra sobretensiones a este producto.
- No conecte elementos no informáticos, como equipos médicos, equipos de asistencia vital, microondas o aspiradoras a este producto.
- Coloque los cables de forma que no se puedan arrancar ni enganchar, ni que nadie los pueda pisar o tropezar con ellos.
- No intente desmontar este producto. Este producto no contiene piezas reemplazables por el usuario. Solamente personal de servicio de fábrica puede realizar reparaciones.
- Si este producto se usa de forma indebida o bien se usa o repara de forma incorrecta, la garantía dejará de ser válida.
- No saque los enchufes de las tomas en uso etiquetadas con una pegatina roja con el texto "No retirar". Son necesarios para que el sistema de carga y las tomas auxiliares del armario funcionen.
- **Puerta de servicio:** ábrala solo si se lo pide el soporte técnico de V7.

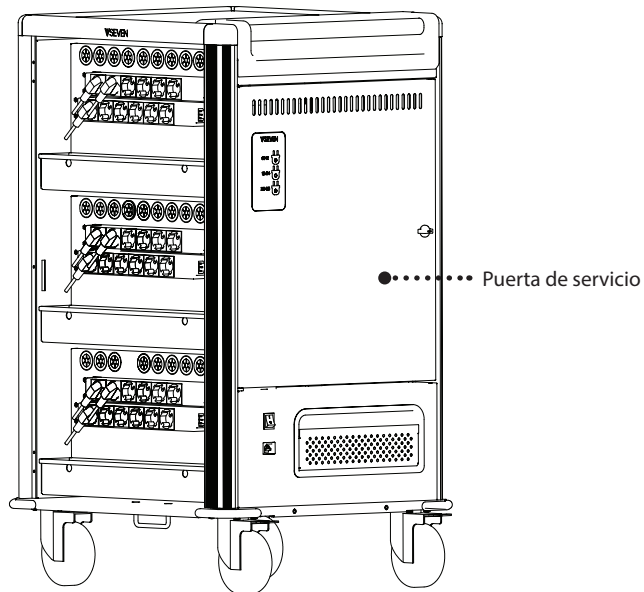

Contenido del paquete

- Cable de alimentación de corriente alterna (CA)
- 2 llaves de puerta de servicio
- 4 Llaves de puerta del dispositivo/alimentación eléctrica

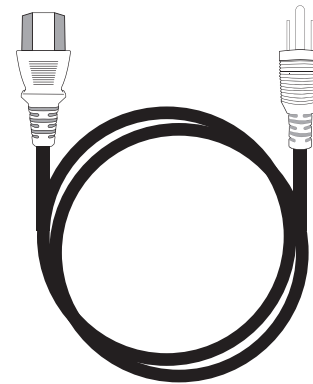
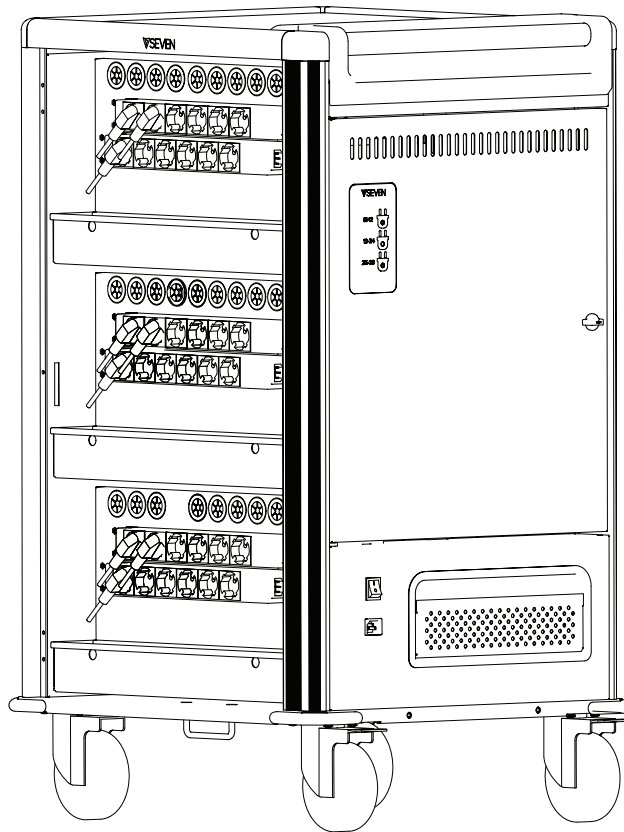

Cable de alimentación de corriente alterna (CA)

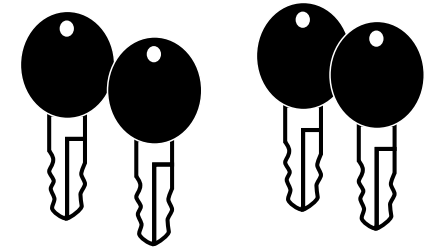

Dispositivo/Alimentación
Llaves de puerta

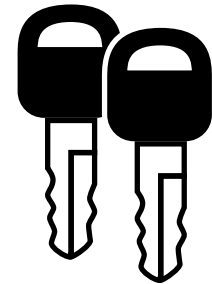

Llaves de puerta de servicio

Diagrama del armario

Parte delantera

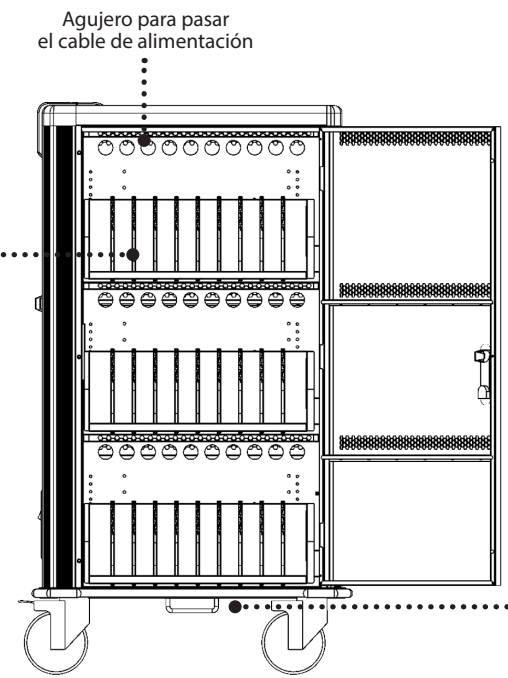
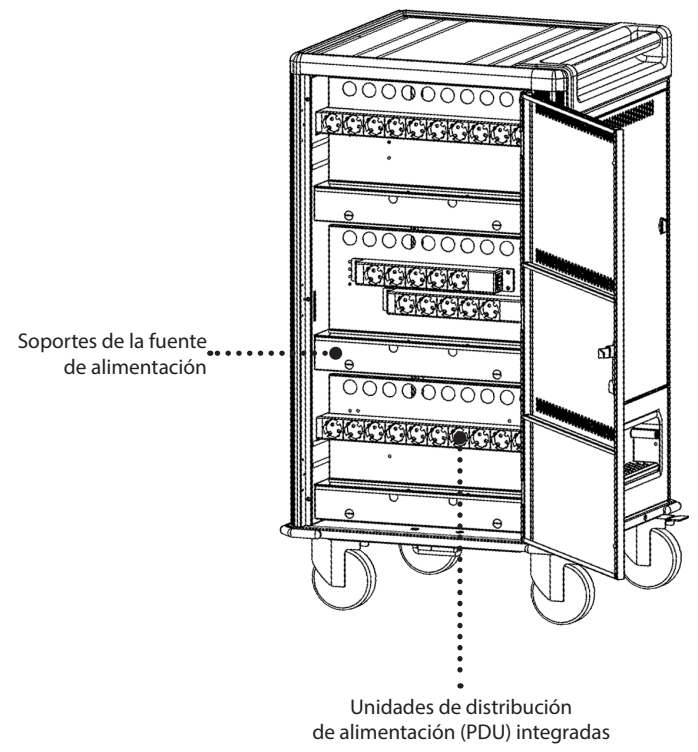
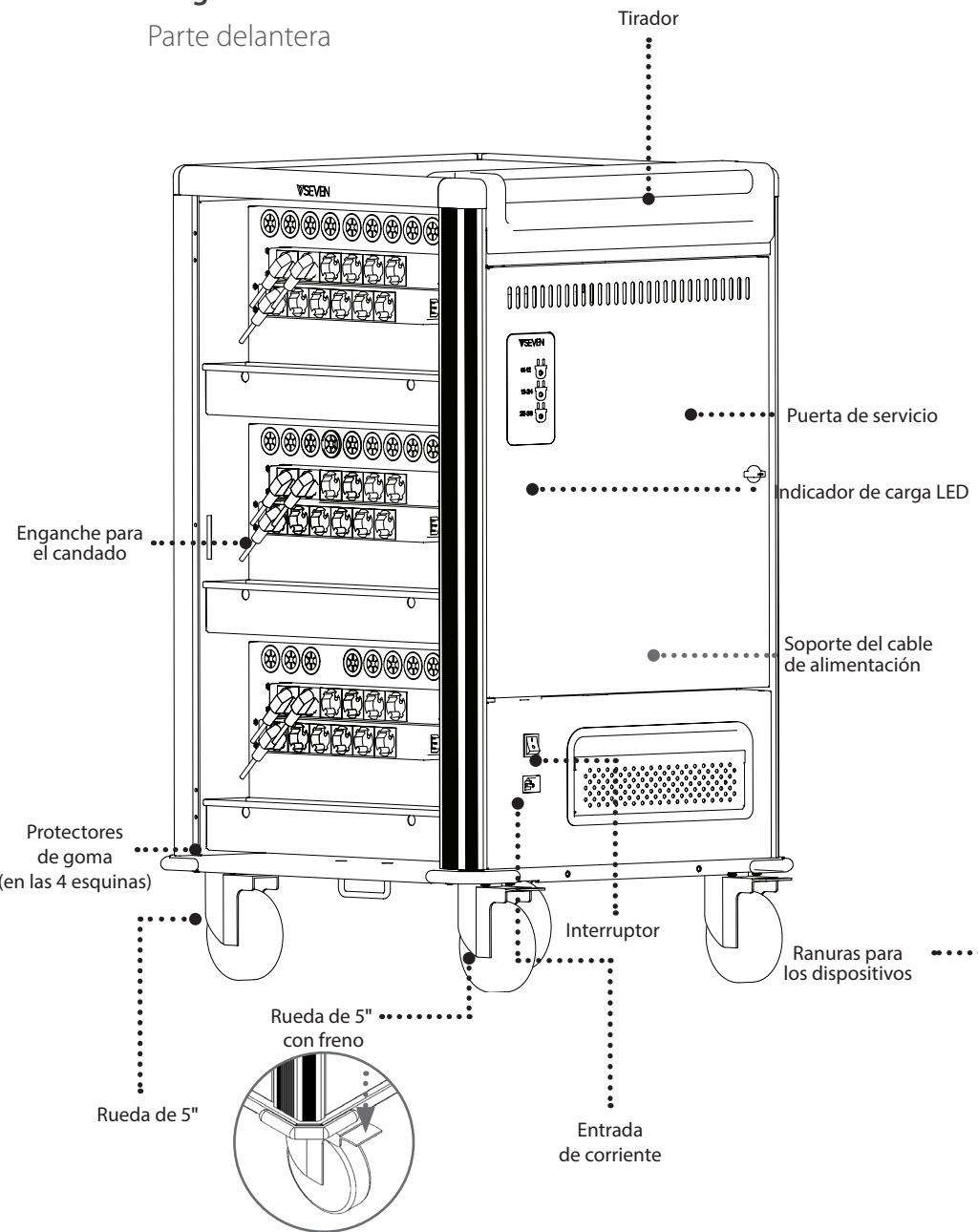

Punto de bloqueo
*Candado de seguridad no incluido

Retirar del palé

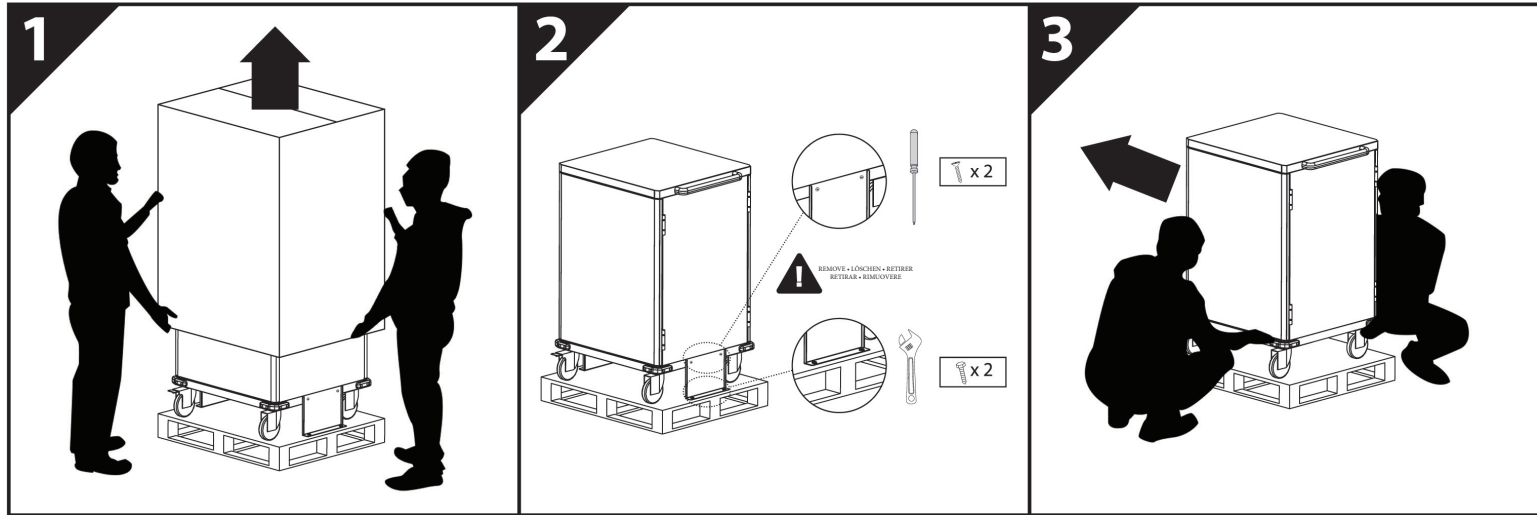

Apertura de puertas
1. Levante el asa

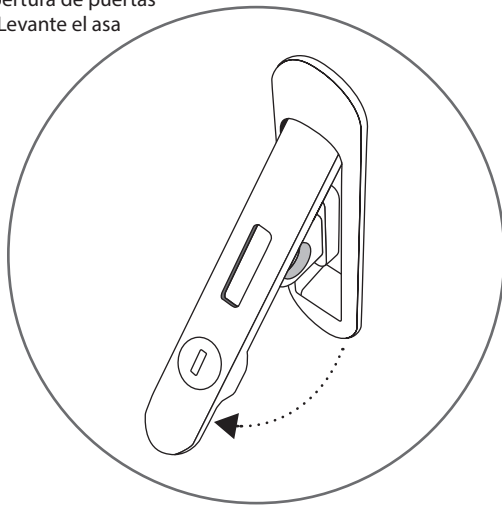

2. Gire a la izquierda
o a la derecha para abrir

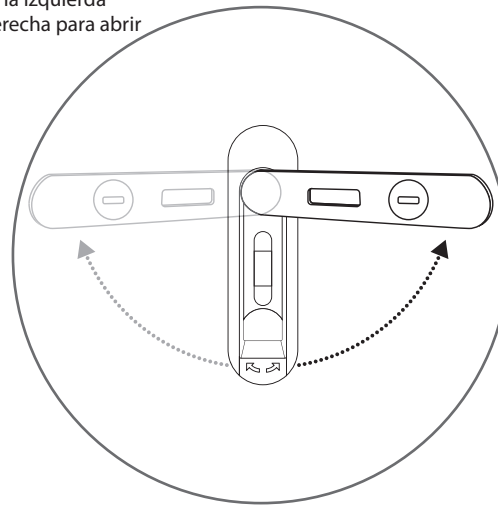

Cierre de puertas

Puerta de servicio - lateral

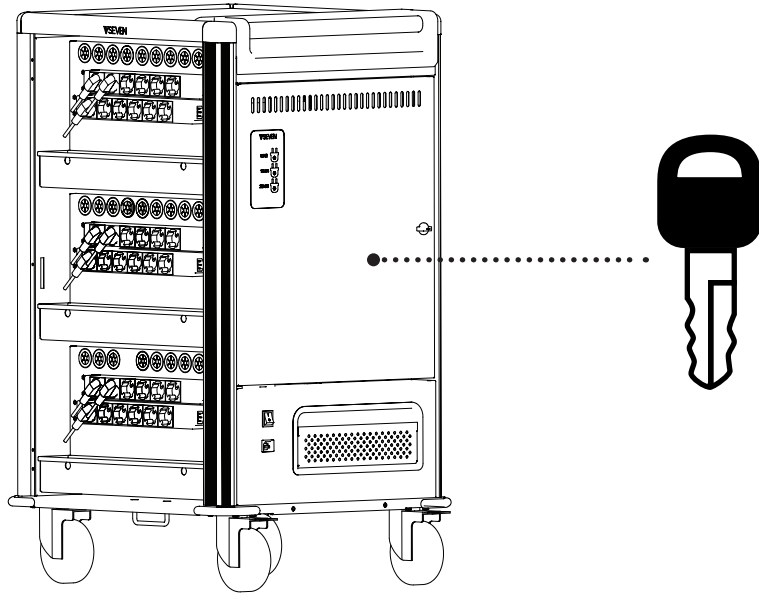

Dispositivo/Puerta de alimentación - Parte delantera y trasera

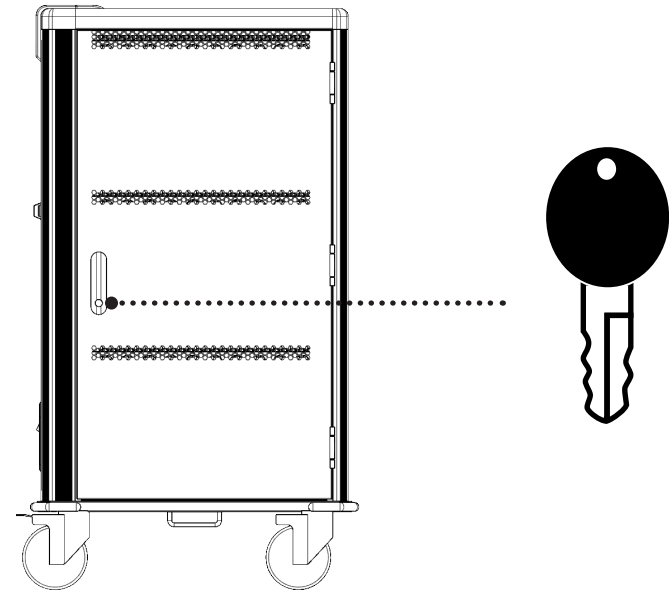

Enganche para el candado

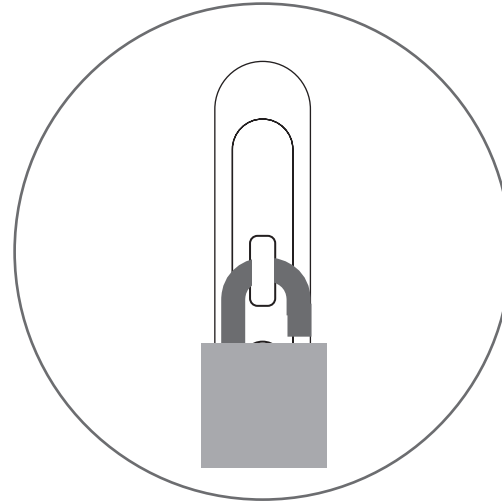
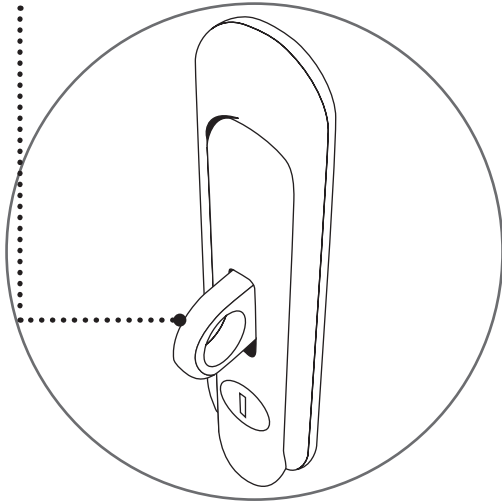

***Candado no incluido**

3 CONFIGURACIÓN

1. Enchufe el armario a la toma

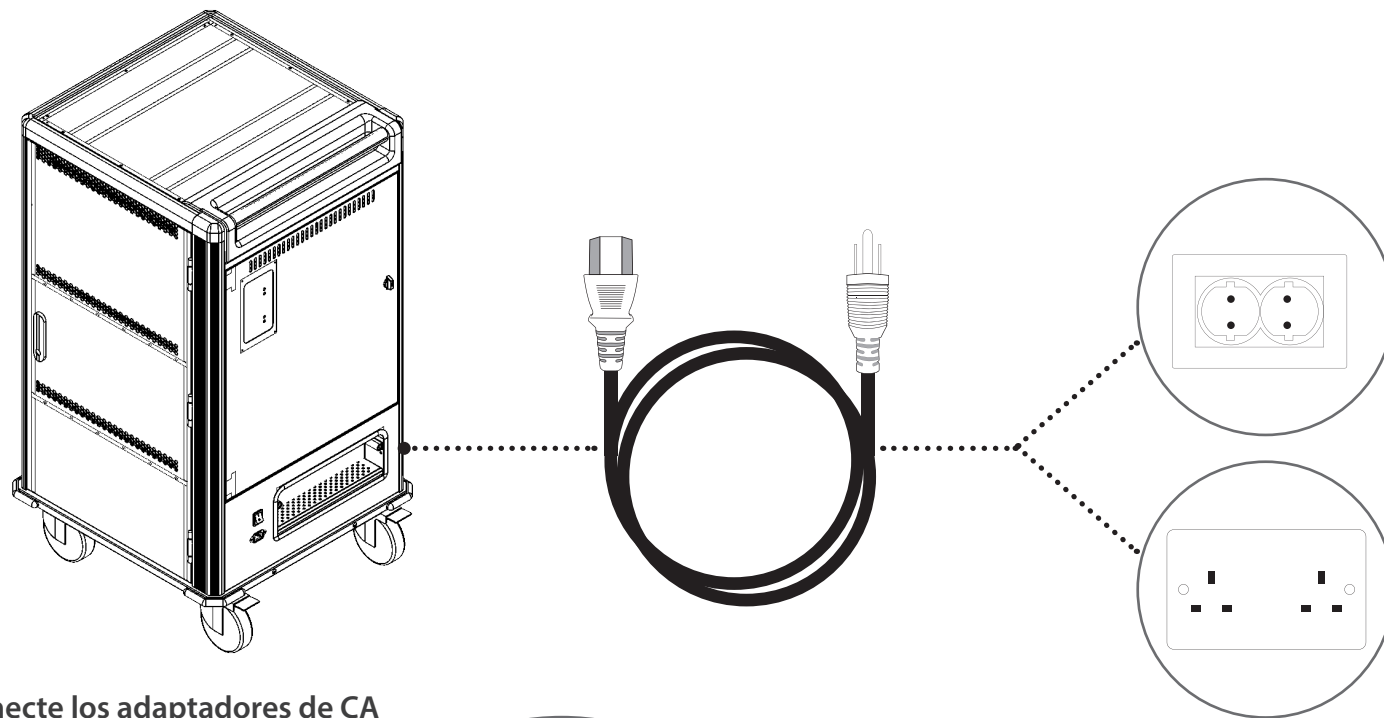

2. Conecte los adaptadores de CA

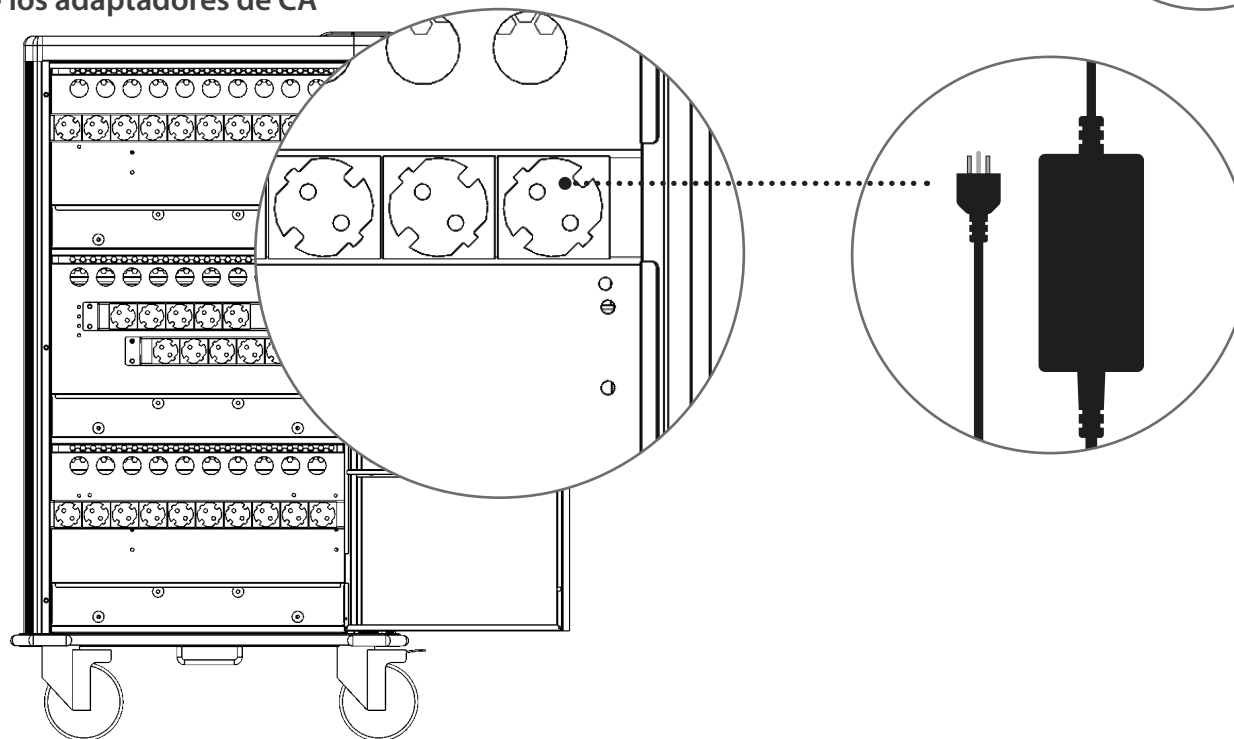

3. Coloque los adaptadores en los soportes para fuente de alimentación

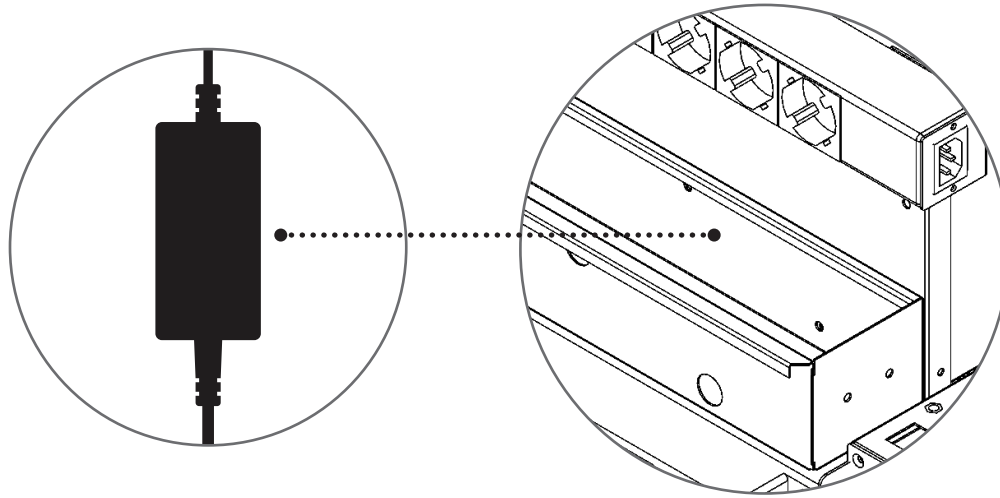

4. Pase los adaptadores por los agujeros

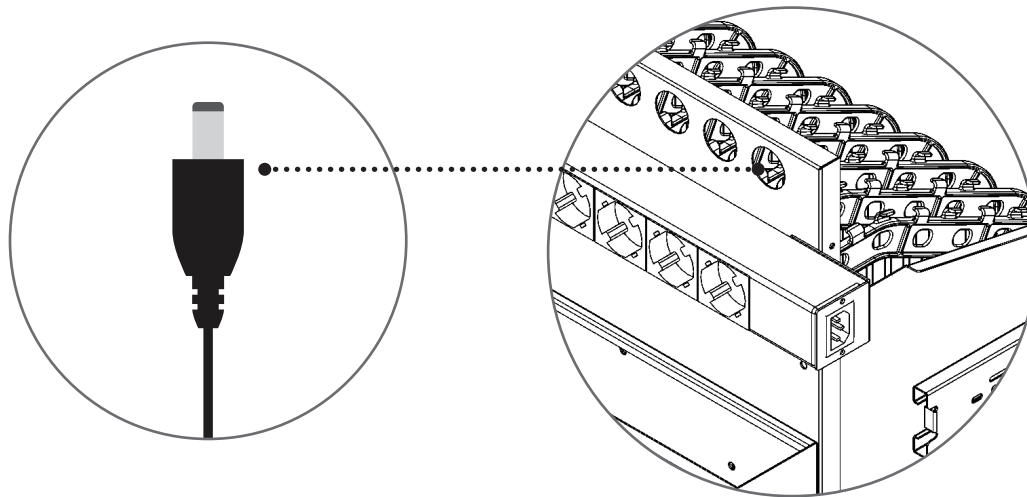

5. Coloque los cables de los adaptadores en los soportes separadores para cables

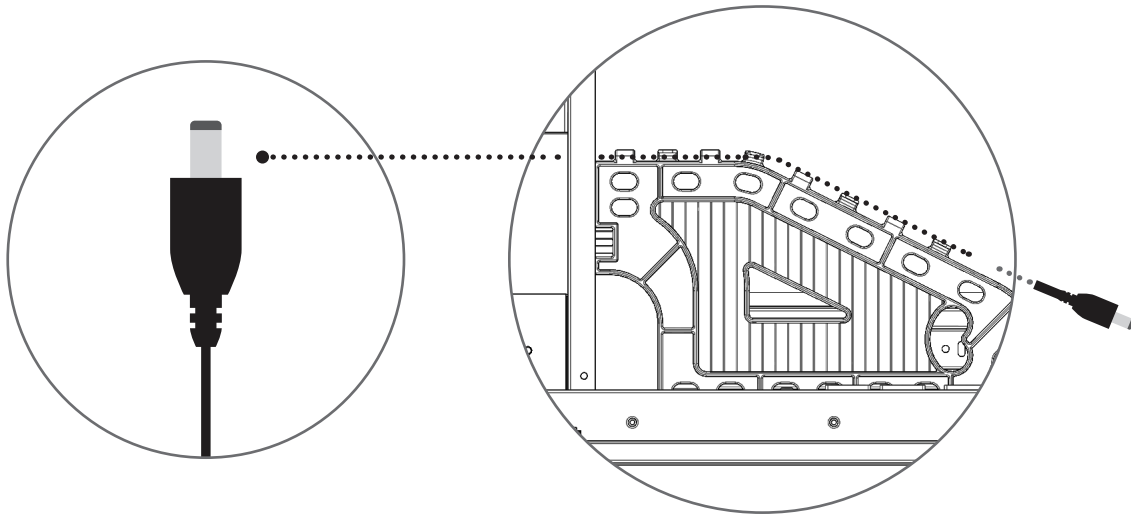

6. Coloque los dispositivos en los separadores

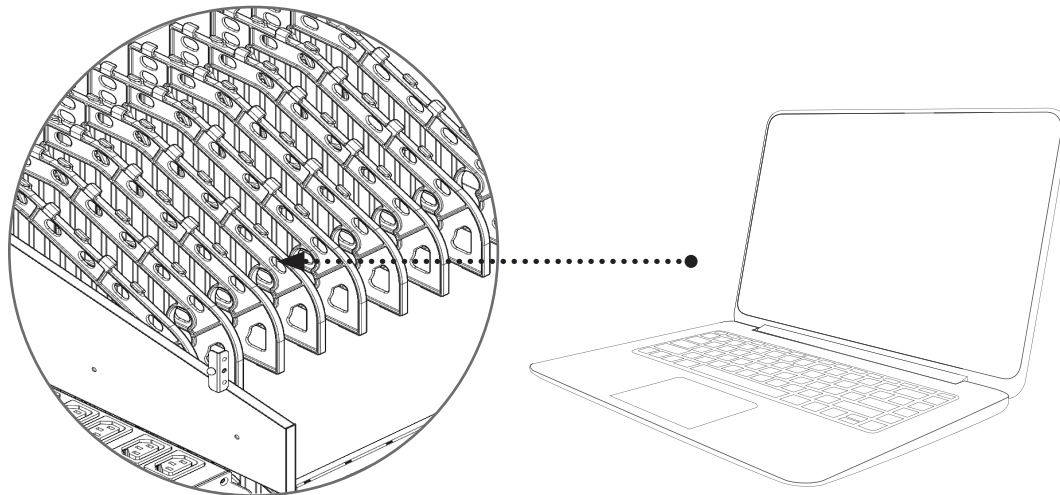

Sistema de carga

Cargar todos sus dispositivos al mismo tiempo puede sobrecargar un circuito típico. Los carros de carga V7 están equipados con un dispositivo de temporización inteligente que cambia automáticamente la fuente de alimentación de CA de una mitad de las tomas de los dispositivos a la otra para ayudar a proteger contra la sobrecarga.

El indicador LED situado en el exterior del carro le mostrará qué aparato se está cargando en ese momento.

Sistema de carga	Sensor de banco inteligente
Cómo carga	Ciclo de carga entre dos grupos. Cuando la corriente total es de menos de 14 amperios, comienza la carga completa
Indicador LED	Azul (encendido): cargando Apagado: No cargando



El indicador LED se iluminará en azul durante la carga.

CHGCT30

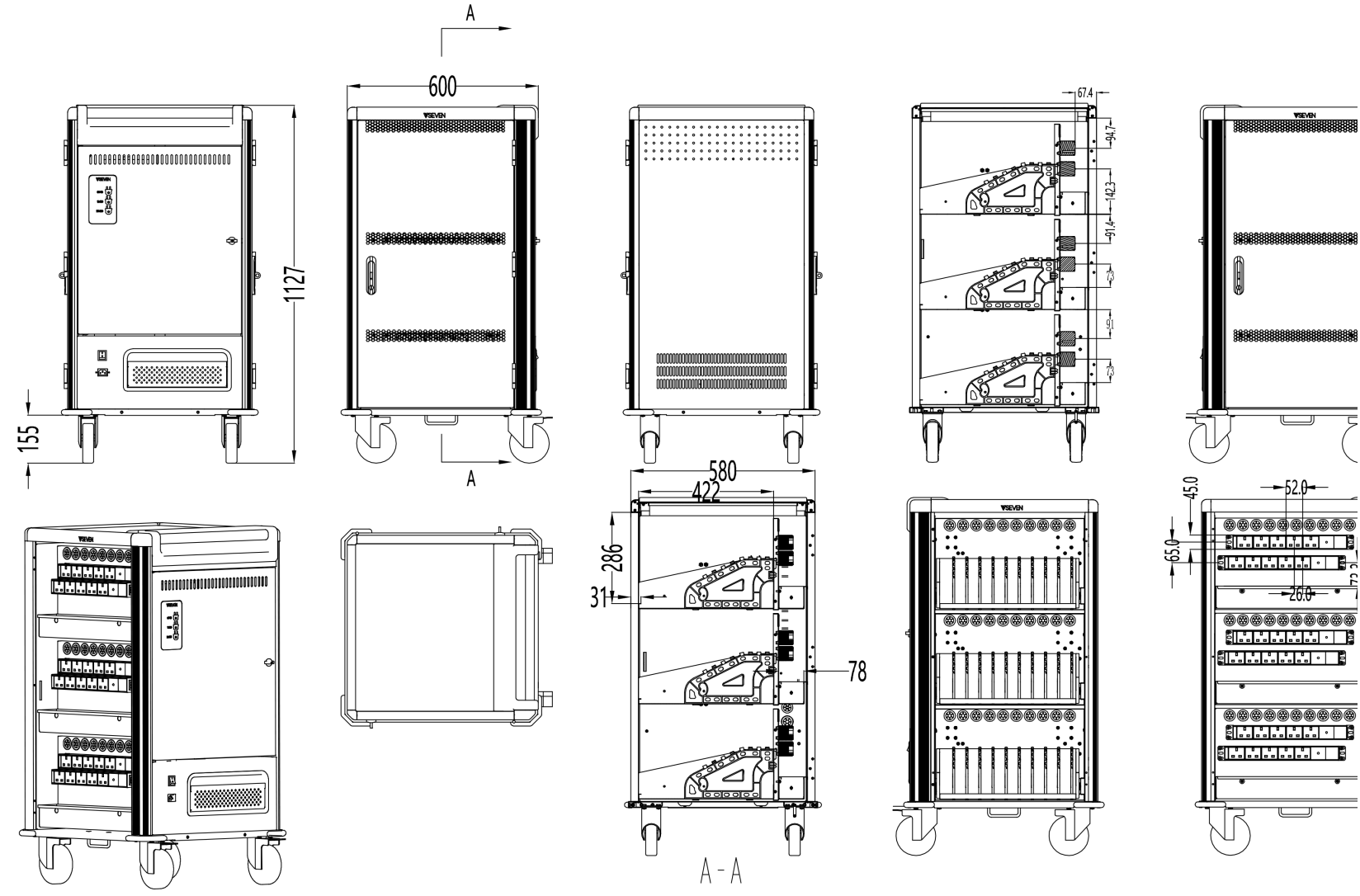

CHGCT36

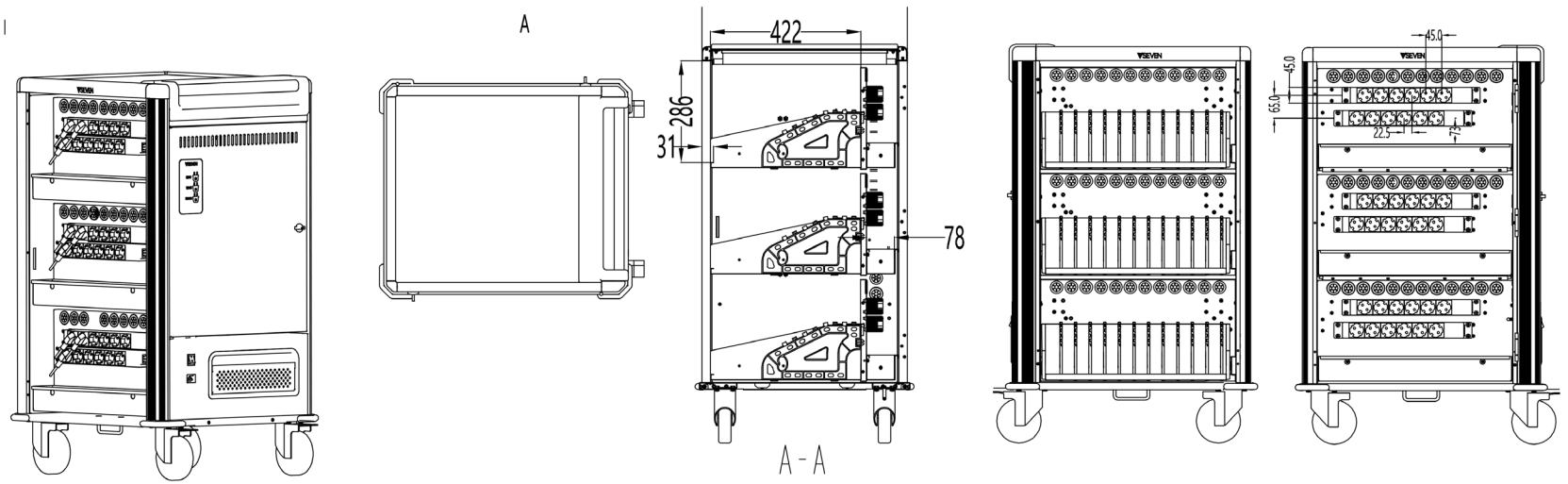
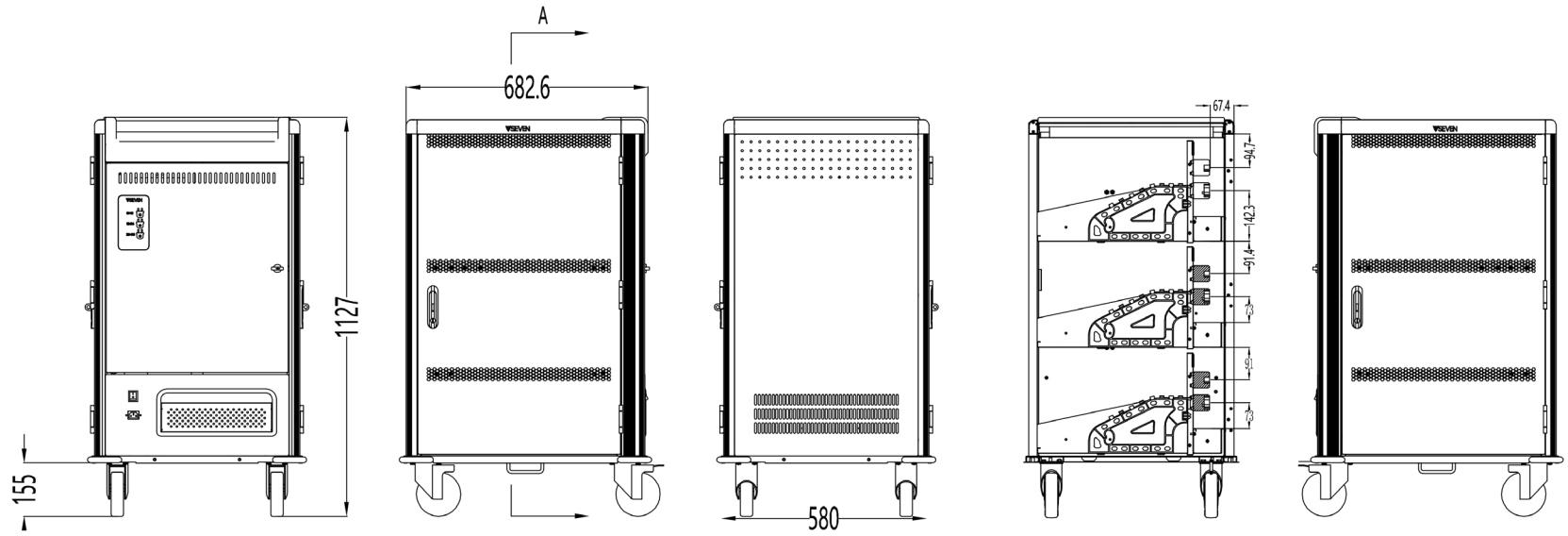

	CHGCT30	CHGCT36
Color	Negro y gris oscuro	Negro y gris oscuro
Material	Acero laminado en frío de alta calidad, calibre 18	Acero laminado en frío de alta calidad, calibre 18
Espacios para dispositivos numerados	30	36
Organización y comodidad	Separadores flexibles para dispositivos con canales para cables y ranuras para dispositivos numeradas, ranuras para adaptadores de corriente numeradas con gestión de cableado, tirador de empuje empotrado	Separadores flexibles para dispositivos con canales para cables y ranuras para dispositivos numeradas, ranuras para adaptadores de corriente numeradas con gestión de cableado, tirador de empuje empotrado
Garantía	5 Year	5 Year
Contenido del paquete	Armario de carga, 1,83 m (6 pies); cable de alimentación; manual	Armario de carga, 1,83 m (6 pies); cable de alimentación; manual
Tensión de entrada	230VAC, 15A, 60HZ	230VAC, 15A, 60HZ
Tensión de salida	230VAC, 15A, 60HZ	230VAC, 15A, 60HZ
Sistema de carga	Carga inteligente	Intelligent Charging
Tamaño de las ruedas giratorias	5 in (12.7 cm)	5 in (12.7 cm)
Dimensiones del producto	23.62 x 22.82 x 44.37 in (599.94 x 579.62 x 1126.998 mm)	26.89 x 22.83 x 44.47 in (683 x 580 x 1127 mm)
Peso del producto	171.96 lbs (78 kg)	187.39 lbs (85 kg)
Tamaño del paquete	25.98 25.59 x 50.08 in ()	28.94 x 25.59 x 50.08 in (753 x 650 x 1272 mm)
Peso del paquete	205.03 lbs (93 kg)	218.26 lbs (99 kg)
Dimensiones de la ranura para dispositivos	16.61 x 1.38 x 11.25 in (422 x 35 x 286 mm)	16.61 x 1.38 x 11.25 in (422 x 35 x 286 mm)
Dimensiones de la ranura para el adaptador de corriente	3.07x 18.22 x 4.48 in (78 x 463 x 114mm)	3.07x 18.22 x 4.48 in (78 x 463 x 114mm)
Entorno*	"Funcionamiento: de -10 °C a 40 °C; humedad: del 20 % a 80 % de humedad relativa Almacenamiento: de -40 °C a 60 °C; humedad: del 20 % a 90 % de humedad relativa"	"Funcionamiento: de -10 °C a 40 °C; humedad: del 20 % a 80 % de humedad relativa Almacenamiento: de -40 °C a 60 °C; humedad: del 20 % a 90 % de humedad relativa"

*Nota: Para este armario de carga solamente. Compruebe las especificaciones del entorno de los dispositivos que está almacenando.

Chariot Classe Mobile

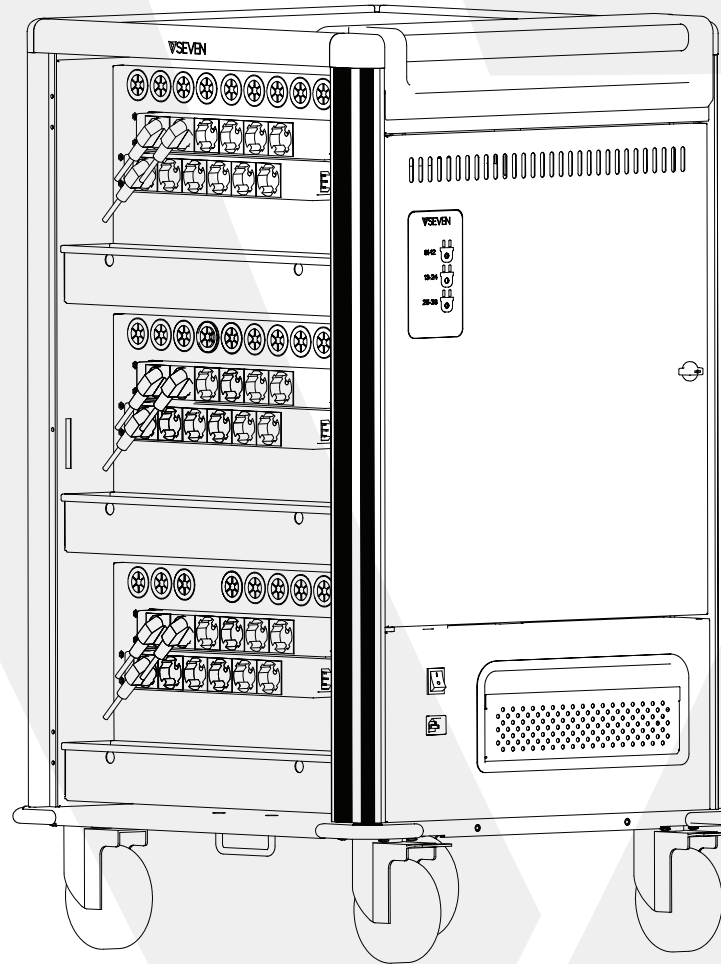

CHGCT30-2E
CHGCT30-2K
CHGCT36-2E

TABLER DES MATIÈRES

1 Sécurité et avertissements

2 Démarrage

Contenu du paquet

Schéma du chariot

Déballage

Verrouillage du chariot

3 Installation

Branchement des appareils

Fonctionnalités avancées

4 Spécifications techniques

AVERTISSEMENT

- Afin de réduire les risques d'électrocution, n'utilisez ce produit qu'en intérieur.
- Ce produit est lourd. Soyez prudent lors de la manipulation et gardez à la verticale. N'essayez pas de le déballer ou de le déplacer seul.
- Soyez prudent lors du déballage et conservez l'emballage pour une utilisation ultérieure. Les rayures et les autres dommages causés par une mauvaise manipulation ne sont pas couverts par la garantie.
- Ne laissez personne s'asseoir, se tenir debout ou grimper sur ce produit.
- Ne bloquez pas les orifices de ventilation utilisés pour la circulation de l'air.
- Ne surchargez pas ce produit d'objets lourds que ce soit à l'intérieur ou sur le dessus.
- Avant de déplacer ce produit, débranchez l'alimentation de la prise murale.
- Lorsque vous déplacez ce produit, assurez-vous que le cordon d'alimentation soit bien fixé.
- Ce produit doit toujours être utilisé par des adultes ou sous la surveillance d'un adulte.
- Ne débranchez jamais ce produit de la prise en tirant sur le cordon d'alimentation ou avec des mains mouillées.
- N'utilisez pas de rallonge avec ce produit.
- L'utilisation de tout type de prise autre qu'une prise bipolaire à trois fils avec mise à la terre peut présenter un risque d'électrocution et entraîner une violation des codes électriques locaux.
- En cas d'urgence, débranchez le cordon d'alimentation de la prise d'alimentation CA.
- Ne branchez pas l'entrée de ce produit dans sa propre sortie.
- Ne branchez pas de rallonge, de multiprise ou de parasurtenseur supplémentaire à ce produit.
- Ne raccordez pas d'éléments autres que du matériel informatique à ce produit comme des équipements médicaux, des équipements de maintien des fonctions vitales, des fours à micro-ondes ou des aspirateurs.
- Placez les câbles de façon à ce qu'ils ne puissent pas être tirés ou débranchés et que personne ne puisse marcher ou trébucher dessus.
- N'essayez pas de démonter ce produit. Ce produit ne contient aucune pièce remplaçable par l'utilisateur. Seul le personnel de l'usine peut effectuer des réparations.
- Si ce produit est employé à mauvais escient, est utilisé de manière incorrecte ou est réparé, la garantie sera annulée.
- Ne retirez pas les fiches des prises utilisées portant la mention « Ne pas enlever » avec un autocollant rouge. Celles-ci sont nécessaires pour assurer le bon fonctionnement du système de charge et des prises auxiliaires.
- **Assistance** - Veuillez vous y référer uniquement si vous avez besoin d'une assistance technique V7.

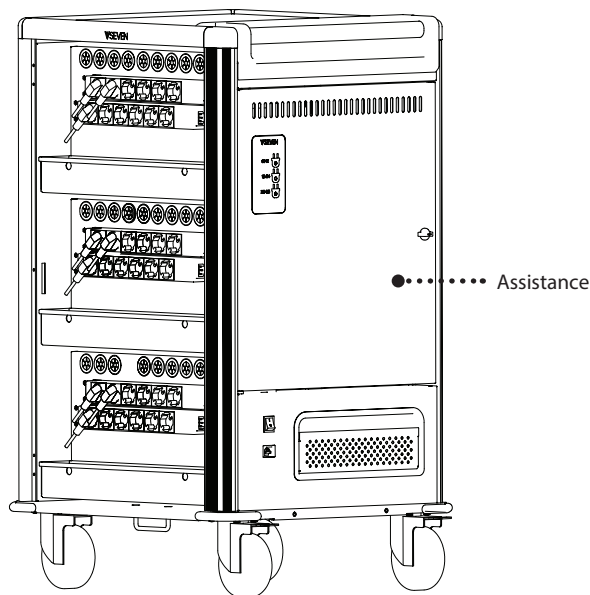

2 DÉMARRAGE

Contenu du paquet

- Cordon d'alimentation
- 2 clés de porte de service
- 4 Clés de porte de l'appareil/de l'alimentation électrique

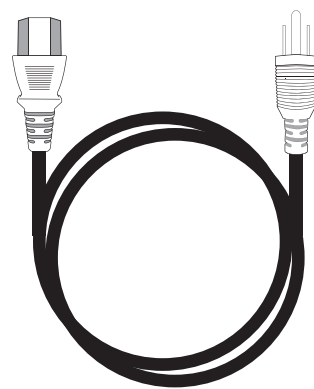
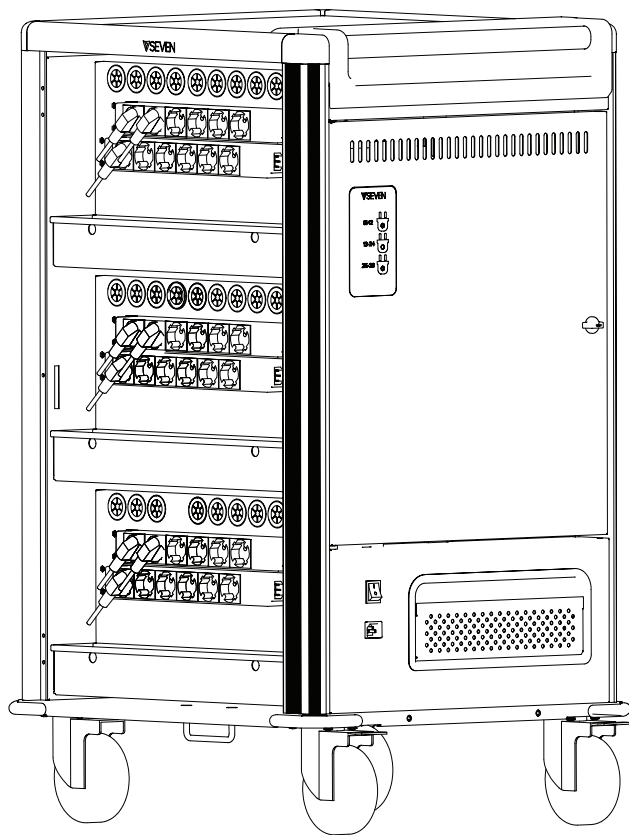

Cordon d'alimentation

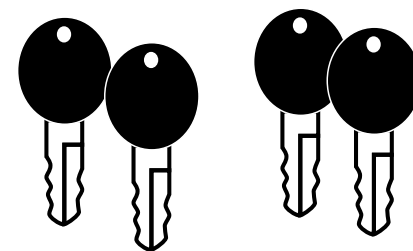

Dispositif/Alimentation électrique Clés de porte

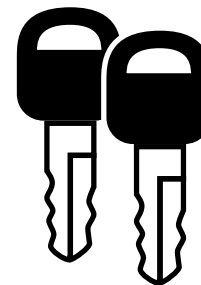

Clés de porte de service

Schéma du chariot

Avant

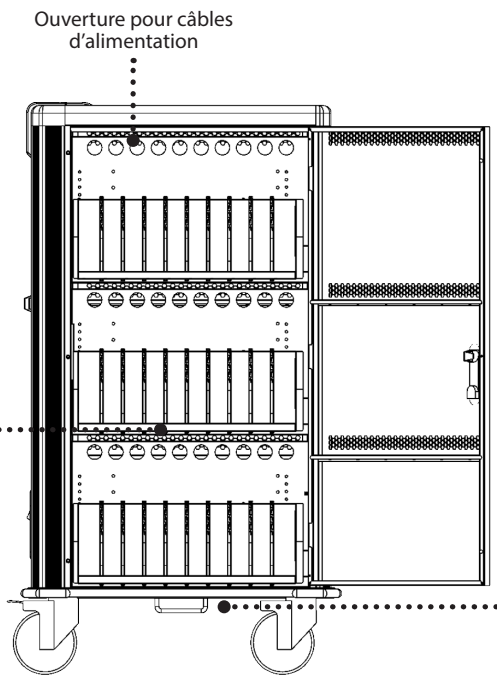
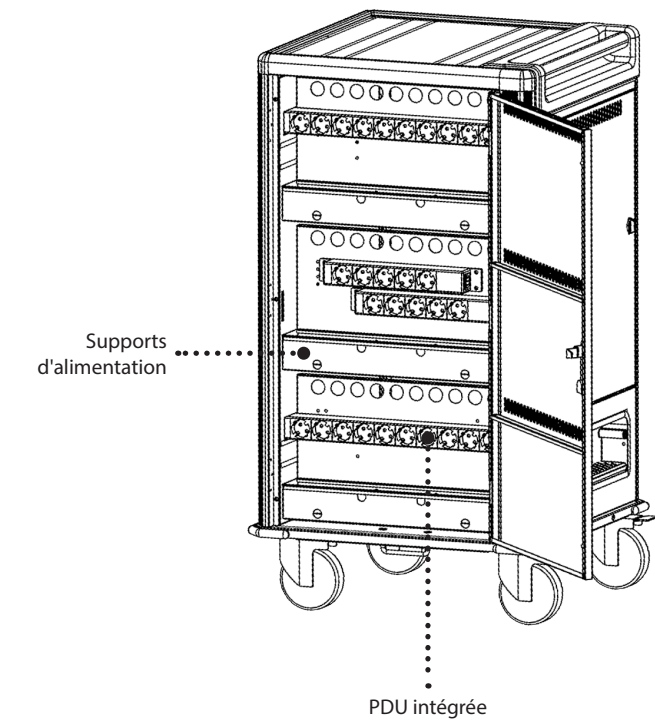
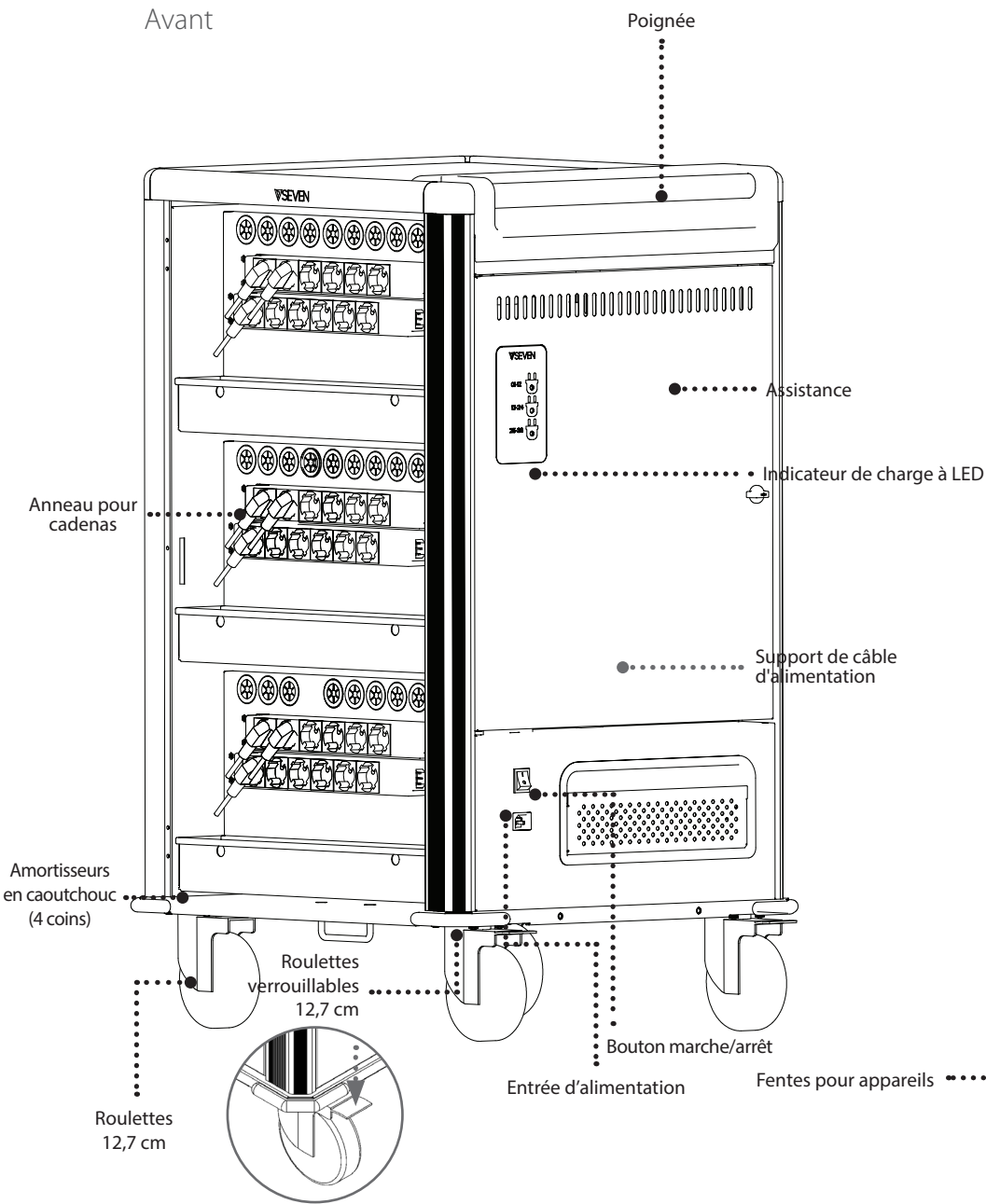

Extraction de la palette

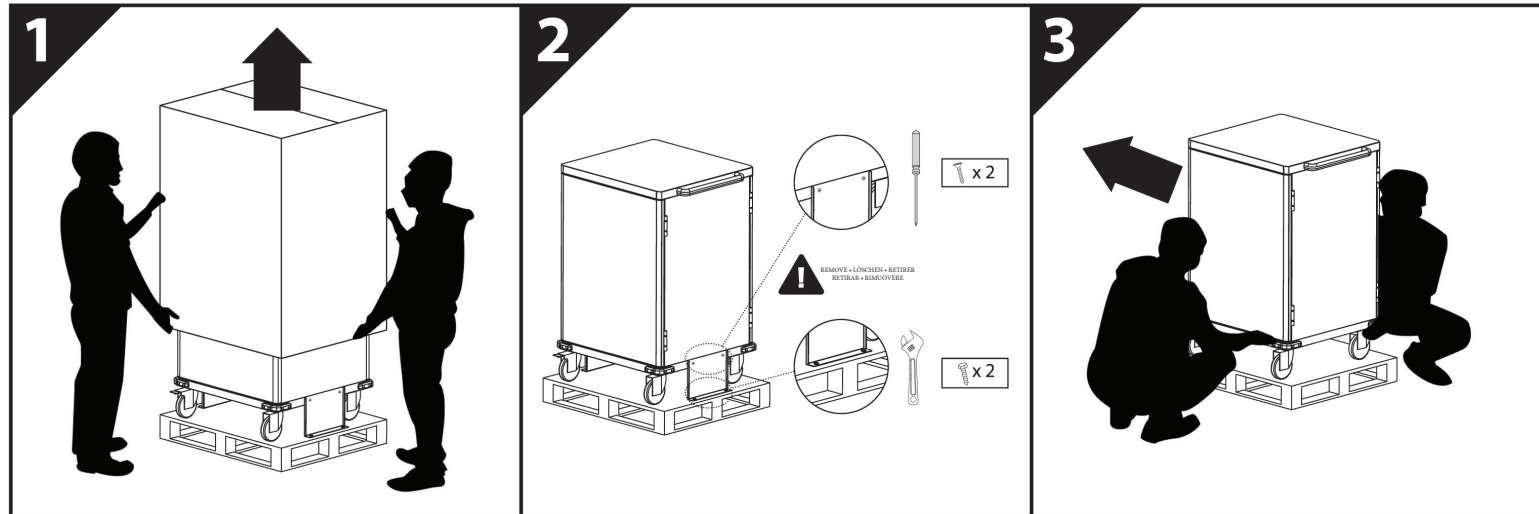

Ouverture des portes
1. Levez la poignée

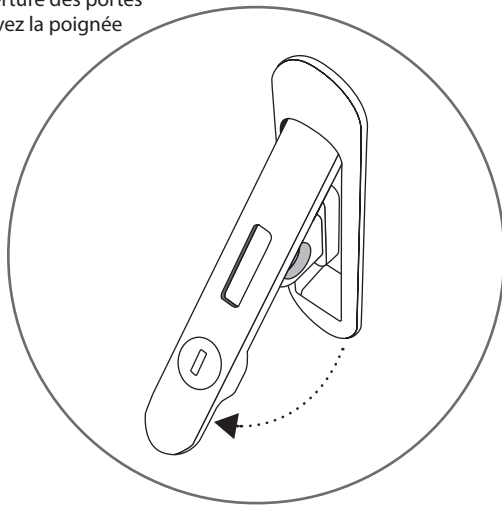

2. Tournez à gauche ou
à droite pour ouvrir

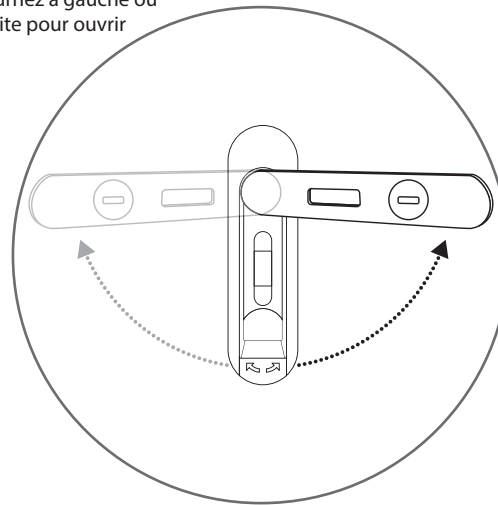

Verrouillage des portes

Porte de service - latérale

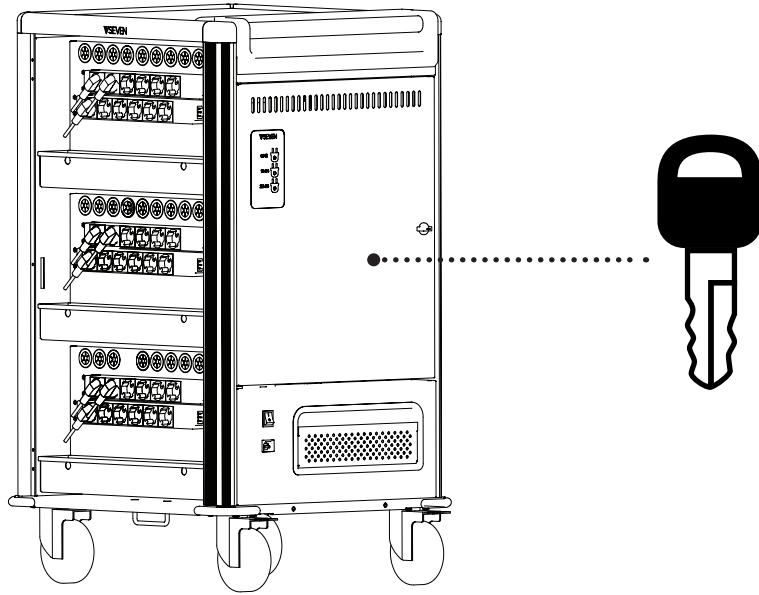

Porte de l'appareil/de l'alimentation - avant et arrière

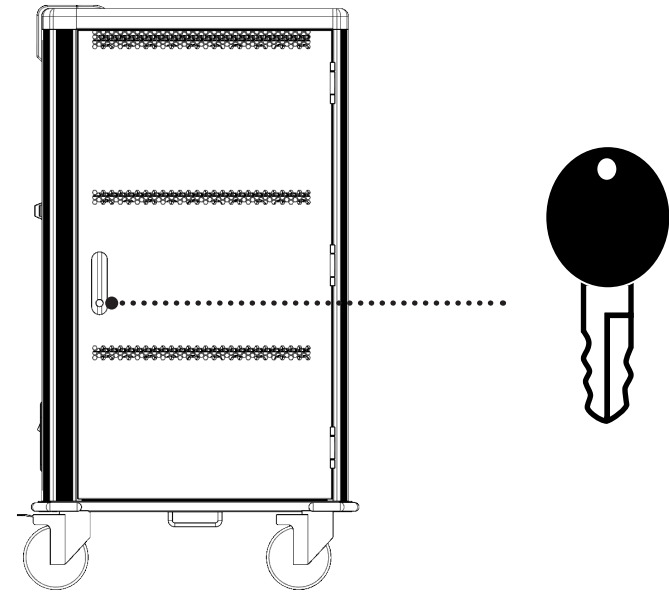

Anneau pour cadenas

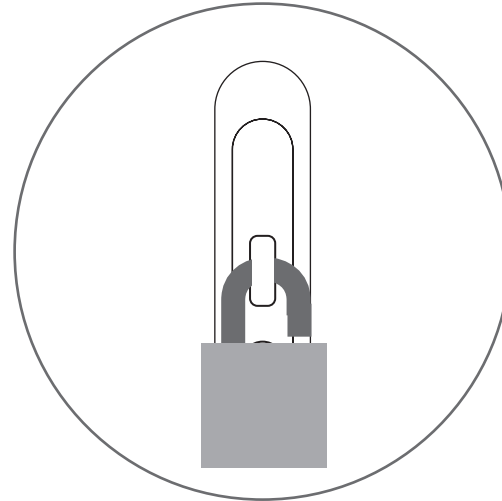
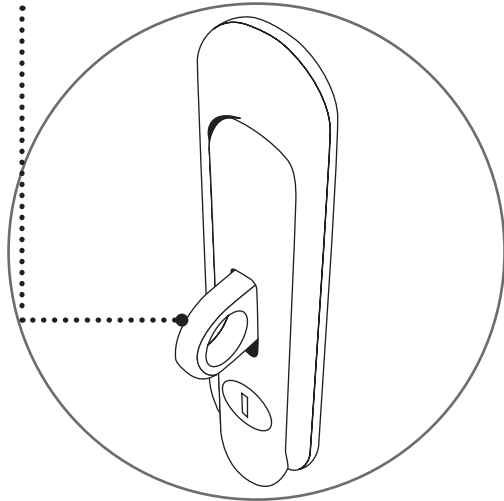

*Cadenas non inclus

3 INSTALLATION

1. Branchez le chariot à une prise

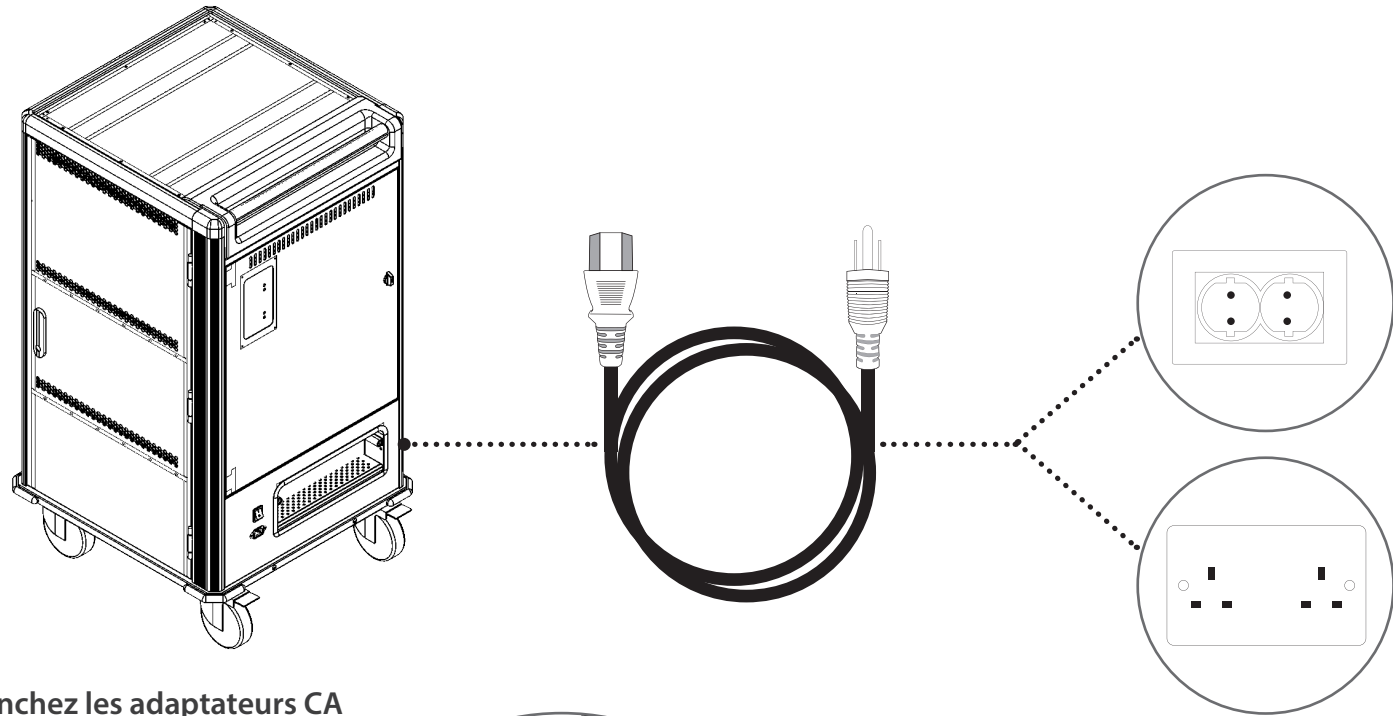

2. Branchez les adaptateurs CA

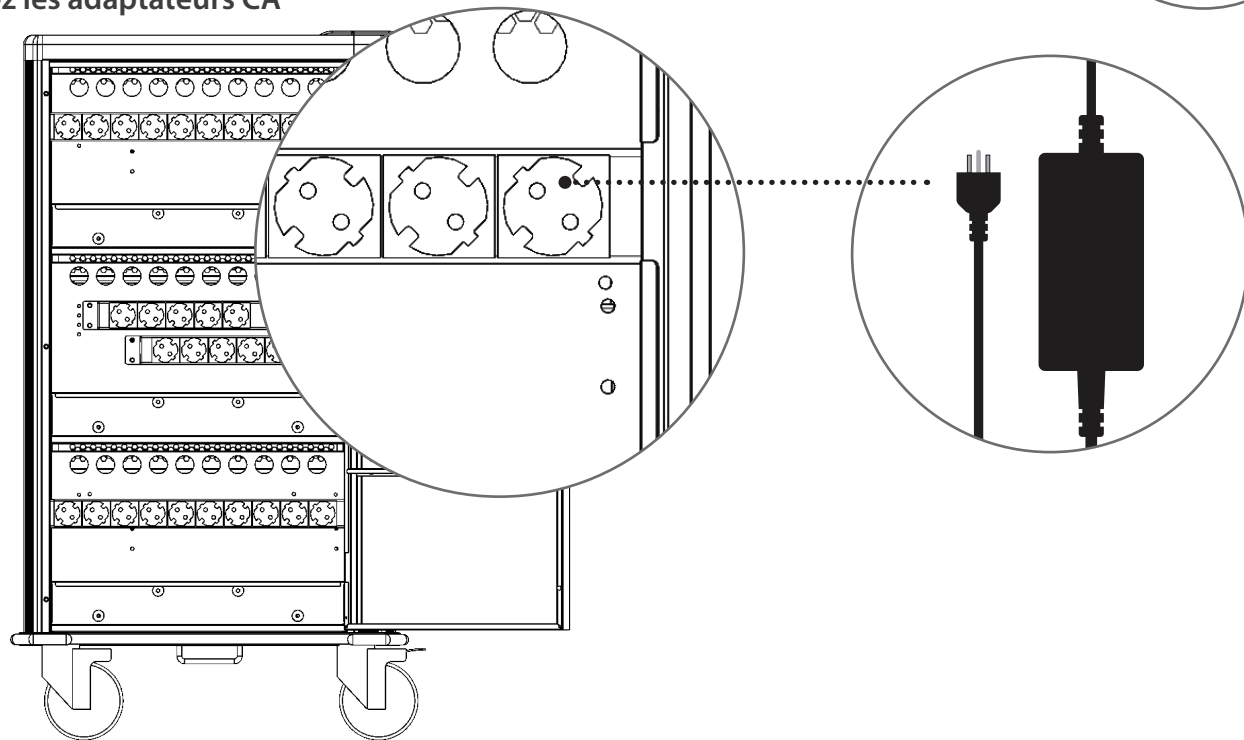

3. Placez les adaptateurs sur les supports d'alimentation

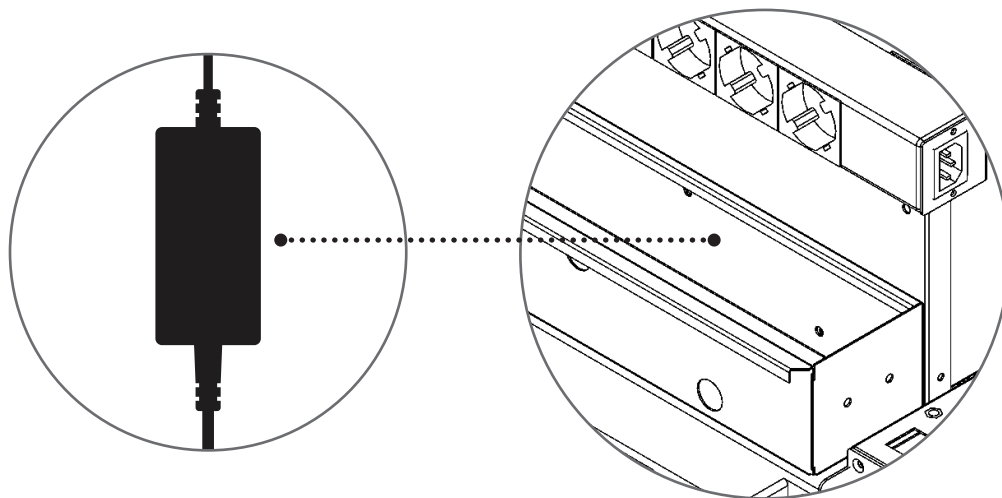

4. Insérez l'embout des adaptateurs à l'intérieur des ouvertures

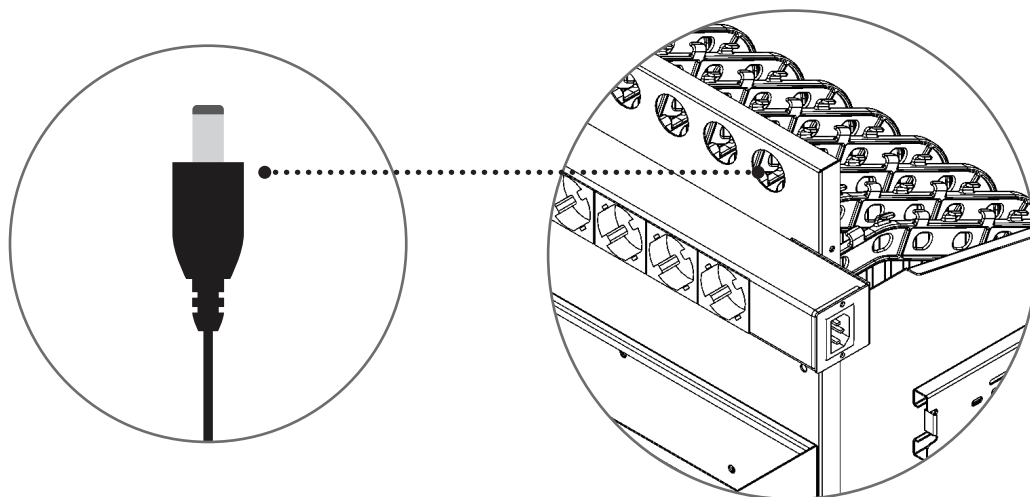

5. Placez les câbles des adaptateurs sur le séparateur de support de câble

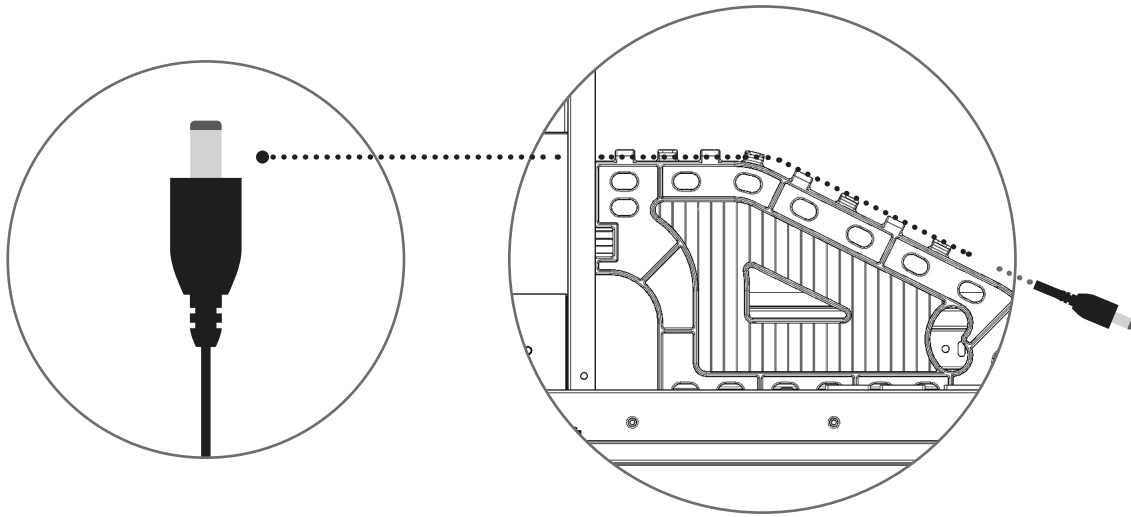

6. Placez les appareils dans les séparateurs

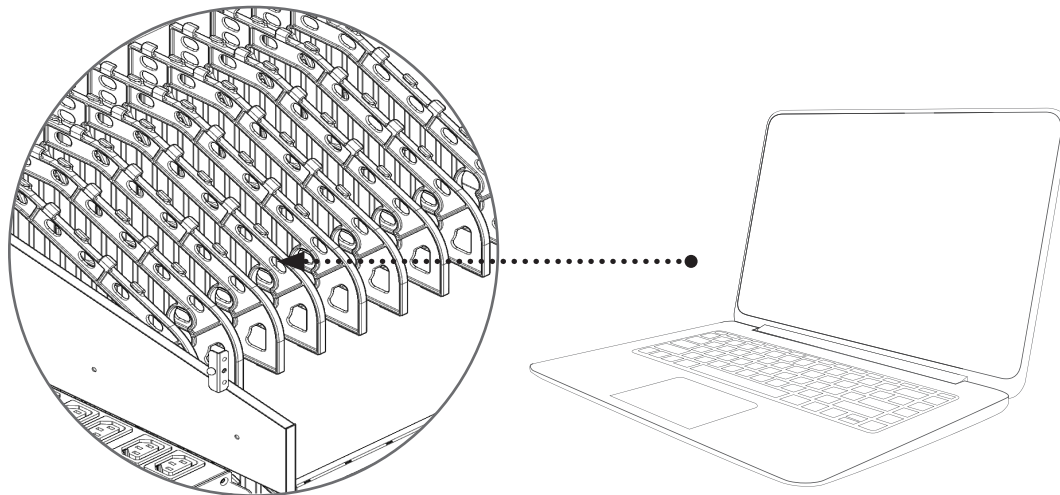

Système de charge

Charger tous vos appareils en même temps peut surcharger un circuit classique. Les chariots de charge V7 sont équipés d'un dispositif de temporisation intelligent qui commute automatiquement l'alimentation CA d'une moitié des prises de l'appareil à l'autre afin d'éviter toute surcharge.

L'indicateur LED situé à l'extérieur du chariot vous indique quel appareil est en train de se charger.

Système de charge	Capteur intelligent
Comment se passe la charge ?	Cycle de charge entre 2 groupes. Lorsque le courant total est inférieur à 14 ampères, la charge complète commence
Indicateur LED	Bleu (allumé) : En charge Éteint : Pas en charge



Le voyant est bleu en cas de charge

CHGCT30

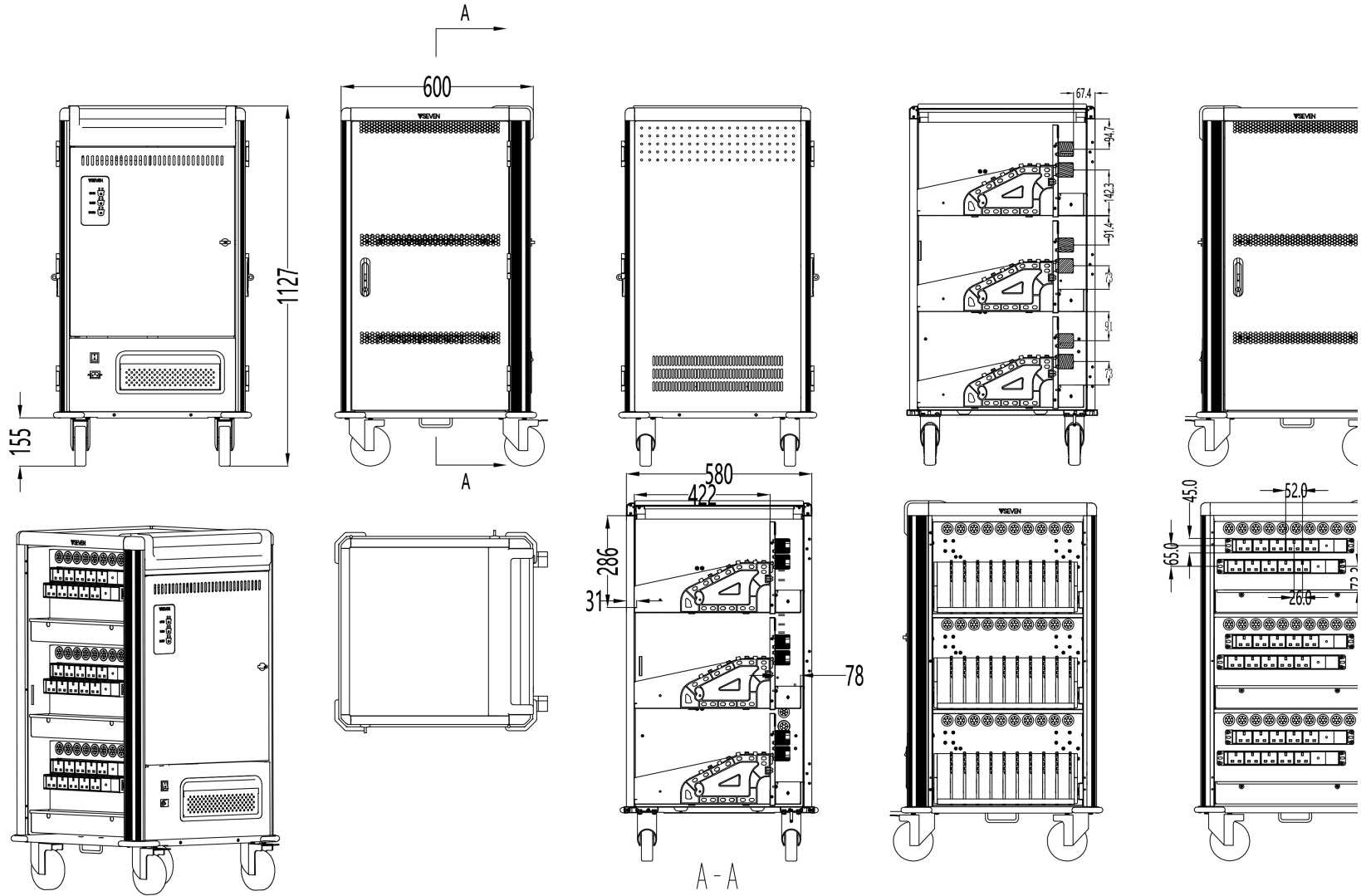

CHGCT36

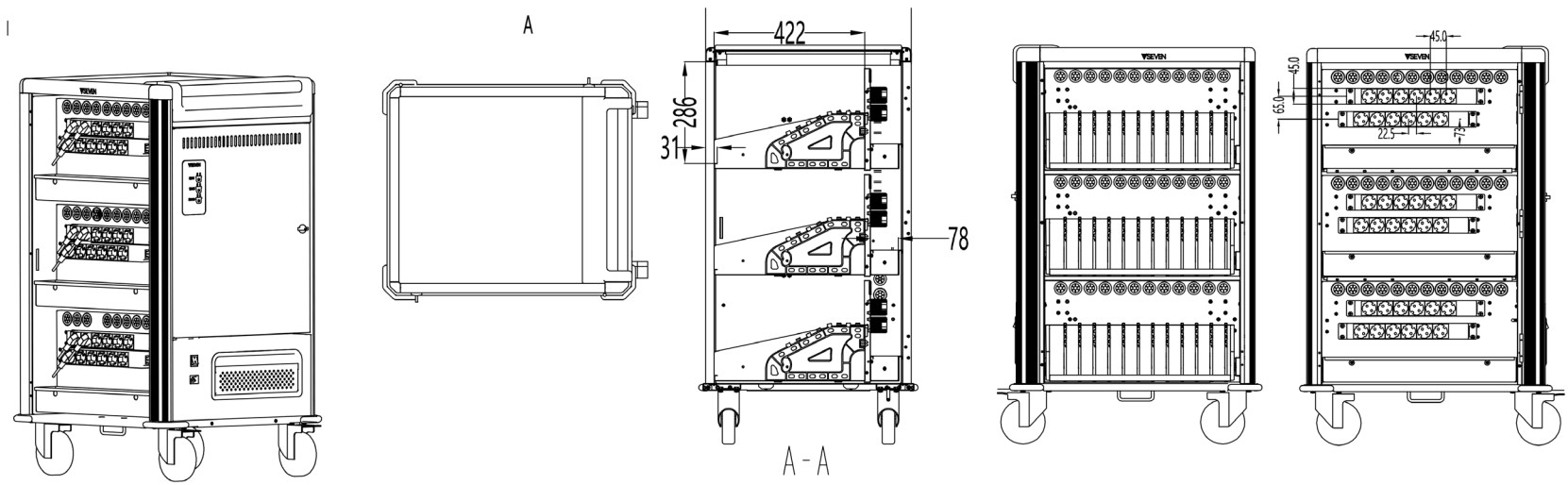
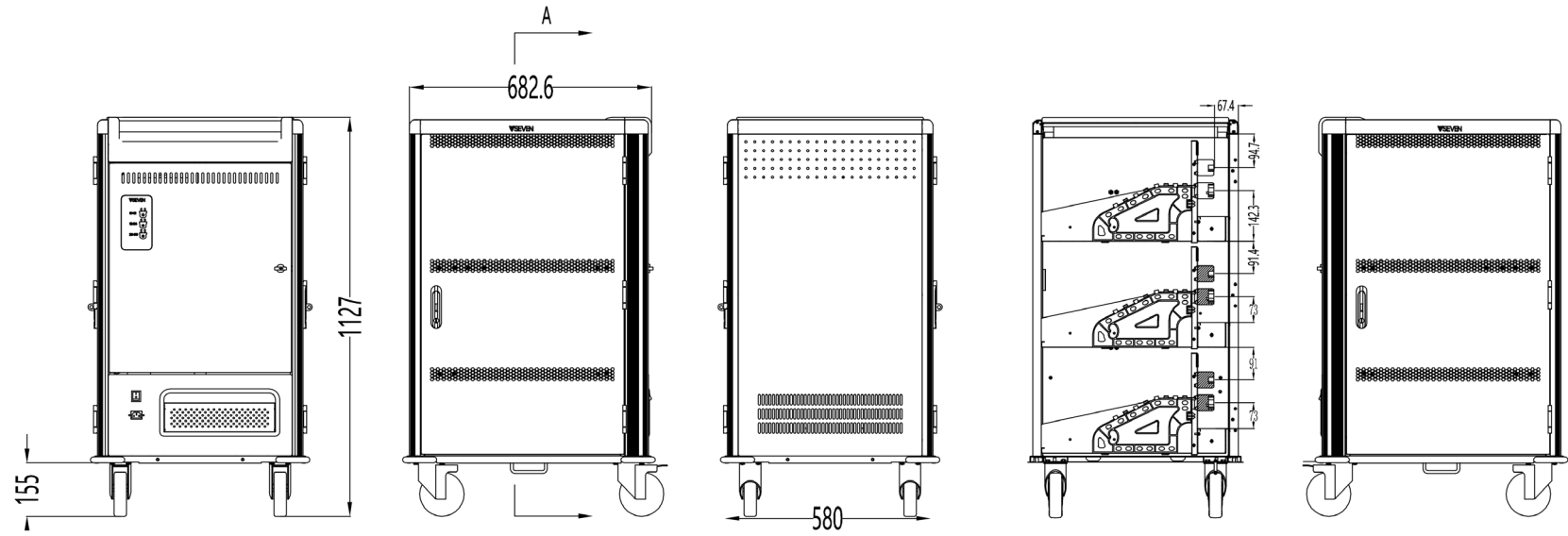

	CHGCT30	CHGCT36
Couleur	Noir et gris foncé	Noir et gris foncé
Matériau	Acier laminé à froid de calibre 18 de haute qualité	Acier laminé à froid de calibre 18 de haute qualité
Espaces des appareils numérotés	30	36
Organisation et praticité	Séparateurs d'appareils flexibles avec réseau de gestion des câbles et fentes pour appareils numérotées, fentes pour adaptateurs d'alimentation numérotées avec gestion des câbles, poignée de manœuvre encastrée	Flexible device dividers with cable channels and numbered device slots, numbered power adapter slots with cable management, recessed push handle
Garantie	5 ans	5 ans
Contenu du paquet	Chariot de charge, câble d'alimentation de 1,83 m, manuel	Chariot de charge, câble d'alimentation de 1,83 m, manuel
Tension d'entrée	230VAC, 15A, 60HZ	230VAC, 15A, 60HZ
Tension de sortie	230VAC, 15A, 60HZ	230VAC, 15A, 60HZ
Système de charge	Intelligent Charging	Intelligent Charging
Dimensions des roulettes	5 in (12.7 cm)	5 in (12.7 cm)
Dimensions du produit	23.62 x 22.82 x 44.37 in (599.94 x 579.62 x 1126.998 mm)	26.89 x 22.83 x 44.47 in (683 x 580 x 1127 mm)
Poids du produit	171.96 lbs (78 kg)	187.39 lbs (85 kg)
Dimensions du colis	25.98 x 25.59 x 50.08 in ()	28.94 x 25.59 x 50.08 in (753 x 650 x 1272 mm)
Poids du paquet	205.03 lbs (93 kg)	218.26 lbs (99 kg)
Dimensions des fentes pour appareils	16.61 x 1.38 x 11.25 in (422 x 35 x 286 mm)	16.61 x 1.38 x 11.25 in (422 x 35 x 286 mm)
Dimensions des fentes pour les adaptateurs d'alimentation	3.07x 18.22 x 4.48 in (78 x 463 x 114mm)	3.07x 18.22 x 4.48 in (78 x 463 x 114mm)
Environnement*	« Fonctionnement : -10 °C à 40 °C Humidité : 20 % à 80 % d'humidité relative	"Operating: -10°C to 40°C Humidity: 20% to 80% RH Storage: -40°C to +60°C Humidity: 20% to 90% RH"

*Remarque : Uniquement pour ce chariot. Consultez les spécifications de l'environnement des appareils que vous stockez.

Carrello di ricarica

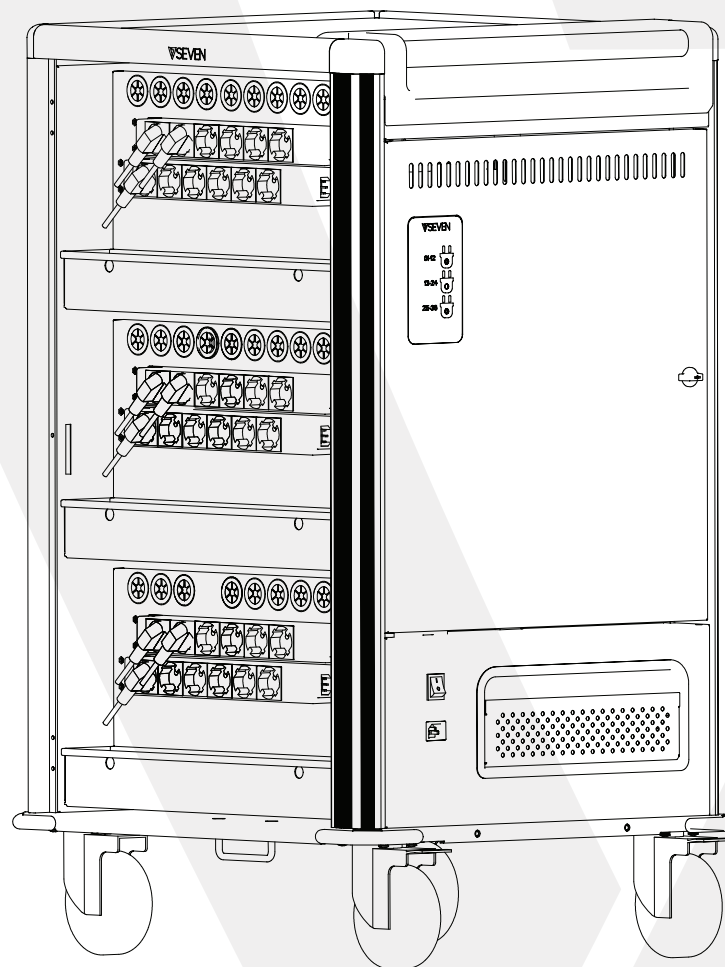

CHGCT30-2E
CHGCT30-2K
CHGCT36-2E

SOMMARIO

1 Sicurezza e avvertenze

2 Operazioni preliminari

Contenuto della confezione

Diagramma del carrello

Disimballaggio

Blocco del carrello

3 Configurazione

Collegamento dei dispositivi

Caratteristiche avanzate

4 Specifiche tecniche

ATTENZIONE

- Per ridurre il rischio di scosse elettriche, utilizzare questo prodotto solo all'interno.
- Questo prodotto è pesante. Prestare attenzione e mantenere il prodotto in posizione verticale. Non tentare di disimballarlo o spostarlo senza assistenza.
- Prestare attenzione durante il disimballaggio e conservare il materiale d'imballaggio per un uso successivo. Graffi e altri danni causati da un uso improprio non sono coperti dalla garanzia.
- Assicurarsi che nessuno si sieda, stia in piedi o si arrampichi su questo prodotto.
- Non ostruire i fori di ventilazione utilizzati per la circolazione dell'aria.
- Non collocare oggetti pesanti sopra o all'interno del prodotto.
- Prima di spostare il prodotto, scollegare l'alimentazione dalla presa a muro.
- Durante lo spostamento del prodotto, assicurarsi che il cavo di alimentazione sia fissato.
- Questo prodotto deve essere sempre utilizzato da adulti o con la supervisione di adulti.
- Non scollegare mai questo prodotto dalla presa con le mani bagnate o tirando il cavo di alimentazione.
- Non utilizzare prolunghe per il collegamento elettrico di questo prodotto.
- Il collegamento a qualsiasi altro tipo di presa diverso da quello a terra a due e tre fili può provocare il rischio di scosse elettriche e violare le normative elettriche locali.
- In caso di emergenza, scollegare il cavo di alimentazione dalla presa di alimentazione CA.
- Non collegare la presa di ingresso del prodotto alla sua presa di uscita.
- Non collegare a questo prodotto prolunghe, ciabatte o protezioni da sovratensioni aggiuntive.
- Non collegare al prodotto oggetti diversi da computer e affini, come, ad esempio apparecchiature mediche, attrezzature di supporto vitale, forni a microonde o aspirapolvere.
- Collocare i cavi in modo che risultino eccessivamente tesi o che possano impigliarsi e in modo che nessuno possa calpestarli o inciamparvi.
- Non tentare di smontare il prodotto. Questo prodotto non contiene parti sostituibili dall'utente. Le riparazioni devono essere eseguite esclusivamente dal personale autorizzato dal produttore.
- Se il prodotto viene utilizzato in modo improprio, non correttamente utilizzato o riparato, la garanzia decade.
- Non rimuovere dalle prese le spine dotate di etichetta rossa "Do not remove" ("Non rimuovere"). Tali spine sono necessarie per il funzionamento del sistema di carica e delle uscite ausiliarie del carrello.
- **Porta di servizio** - Aprire solo se richiesto dal supporto tecnico di V7.

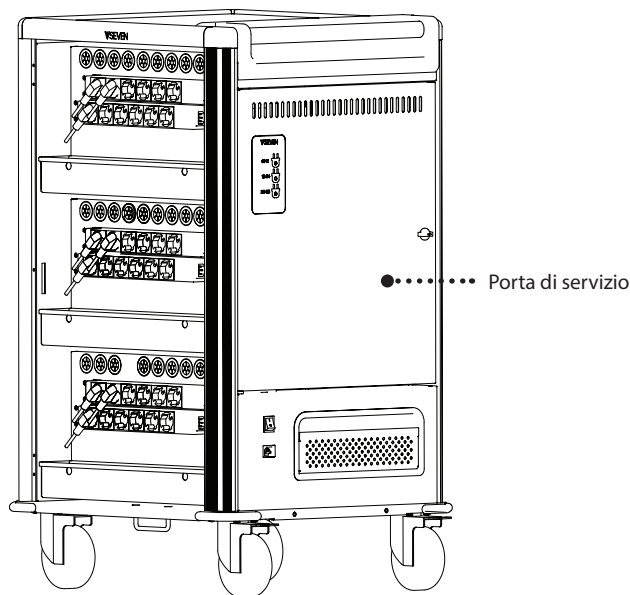

Contenuto della confezione

- Cavo di alimentazione CA
- 2 chiavi della porta di servizio
- 4 Chiavi della porta del dispositivo/alimentazione

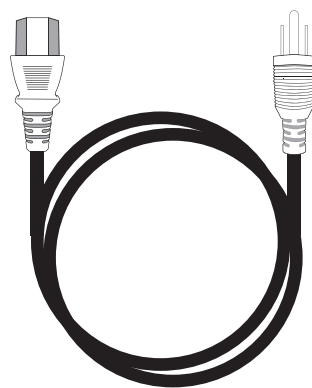
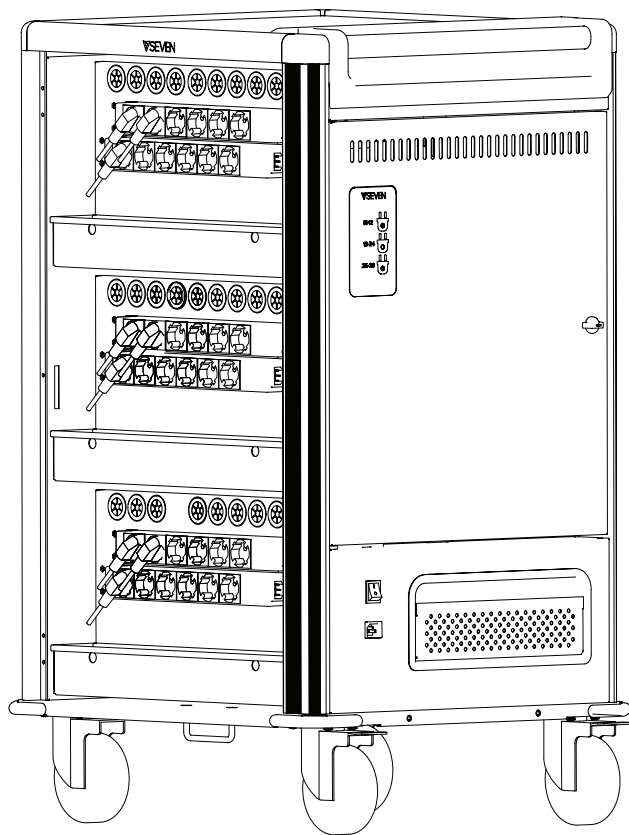

Cavo di alimentazione CA

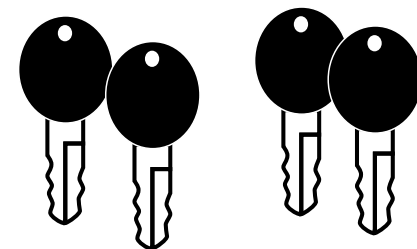

Chiavi della porta del dispositivo/alimentazione

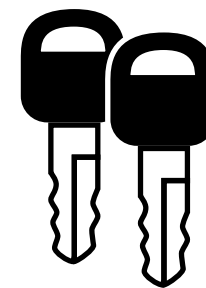

Chiavi della porta di servizio

Diagramma del carrello

Lato anteriore

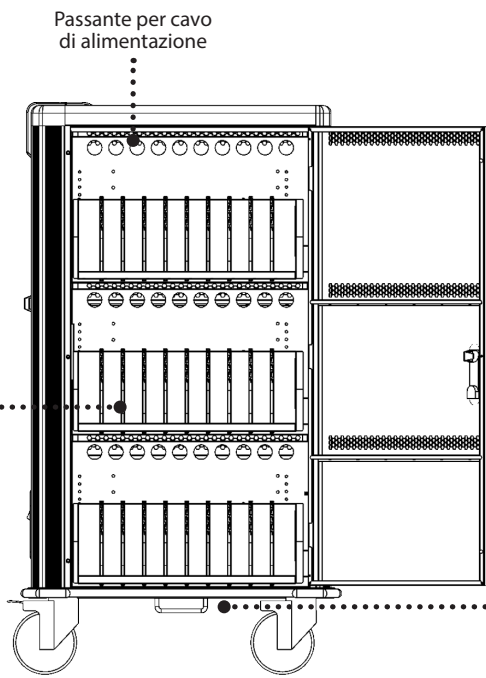
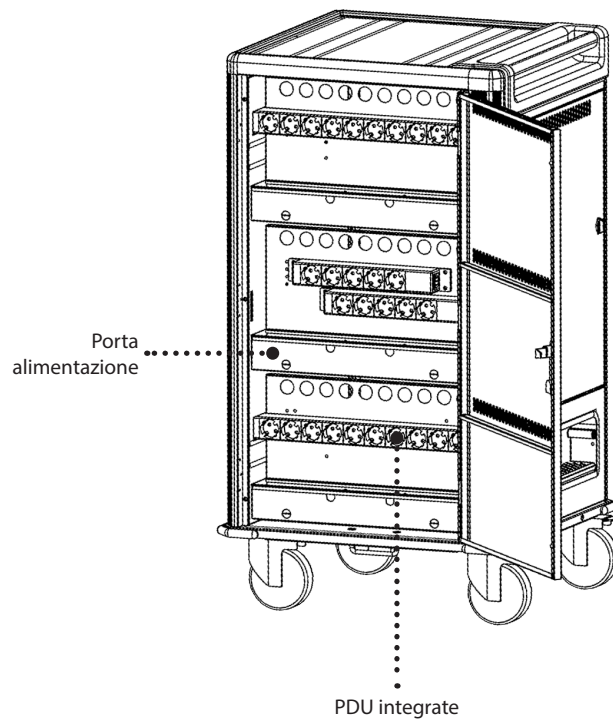
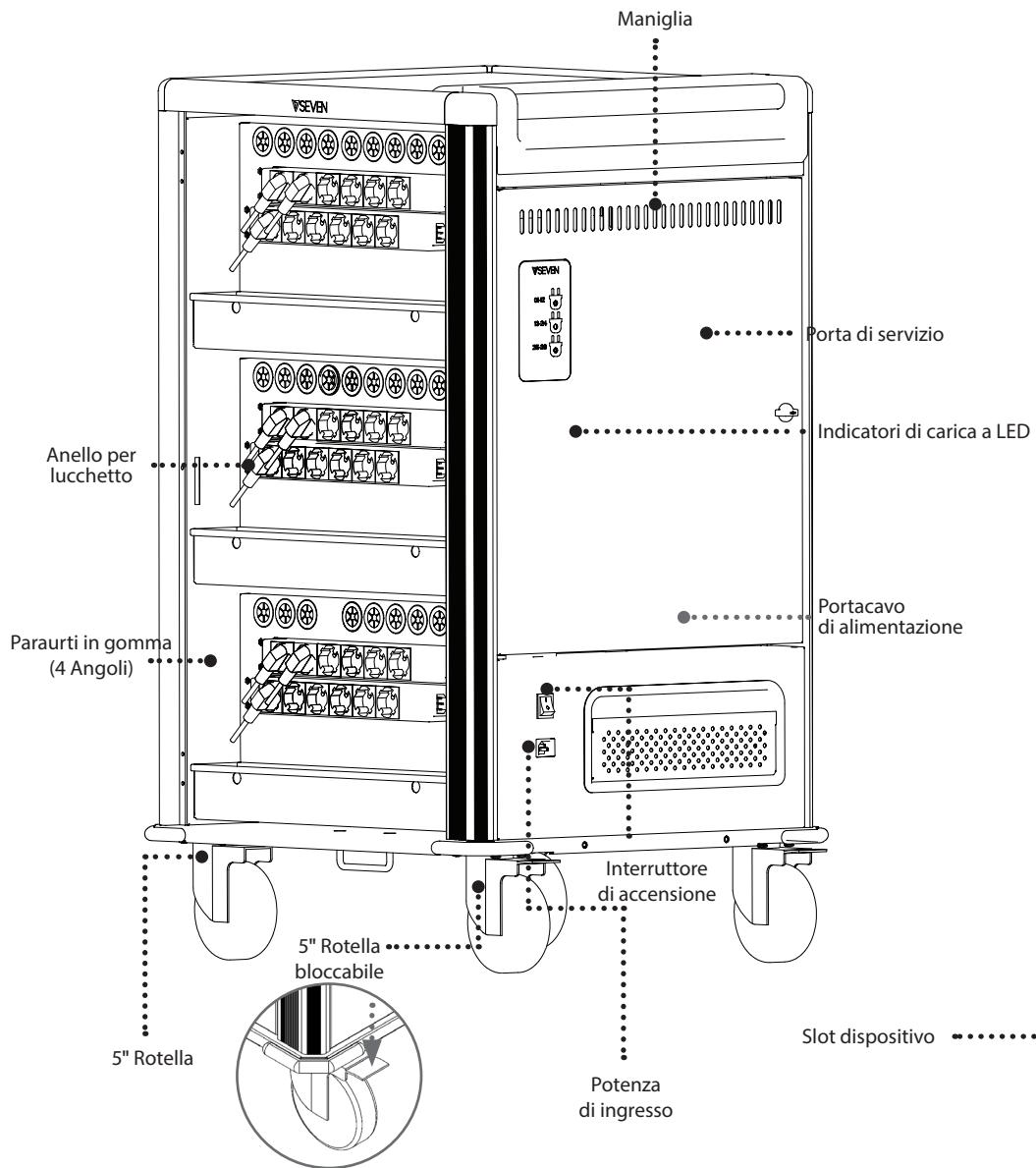

Punto di chiusura
*Dispositivo di chiusura non incluso

Rimuovere l'unità dal pallet

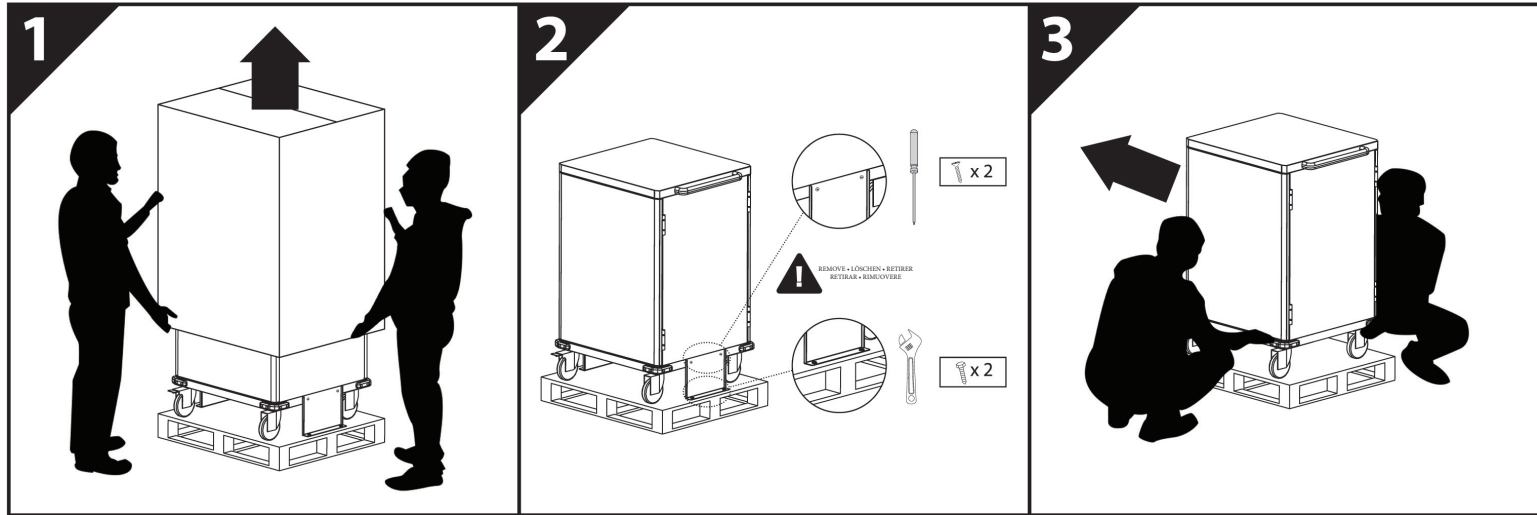

Aprire gli sportelli
1. Sollevare la maniglia

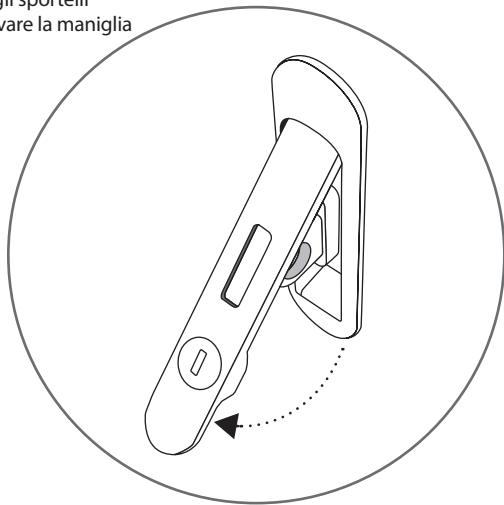

2. Ruotare a sinistra
o a destra per aprire

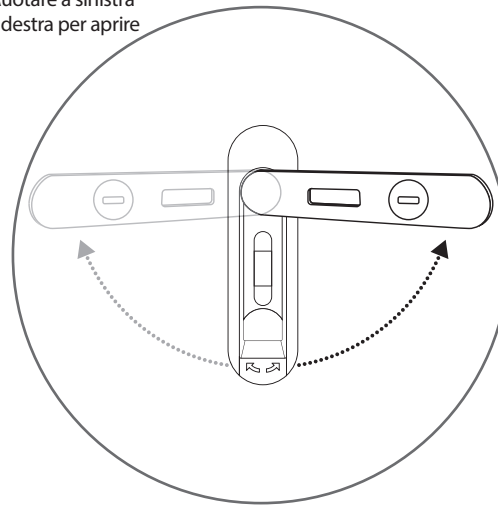

Serrature sportelli

Porta di servizio - laterale

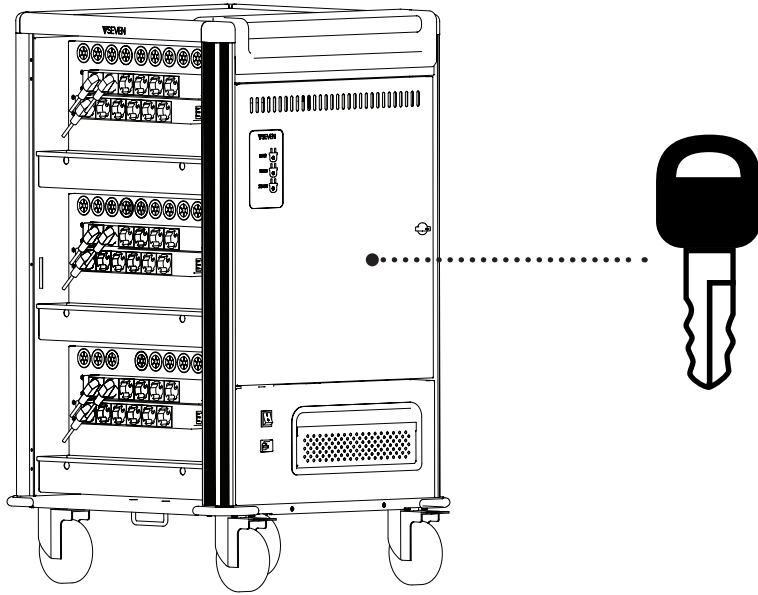

Porta del dispositivo/alimentazione - Parte anteriore e posteriore

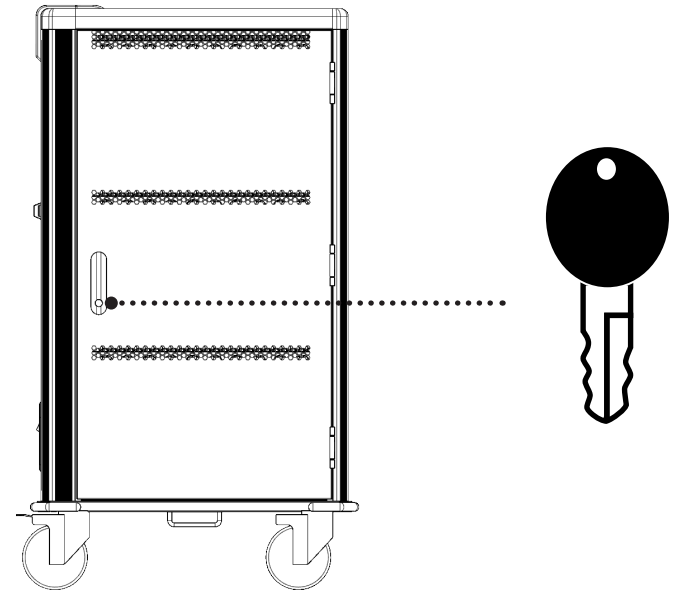

Anello per lucchetto

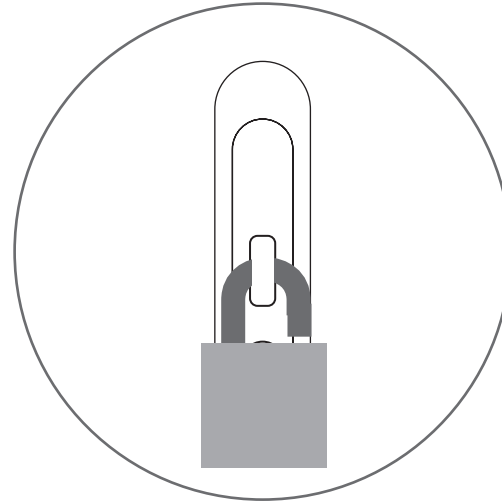
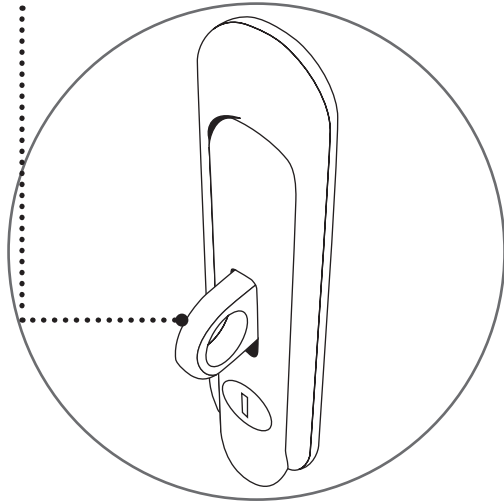

***Lucchetto non incluso**

3 CONFIGURAZIONE

1. Collegare il carrello alla presa

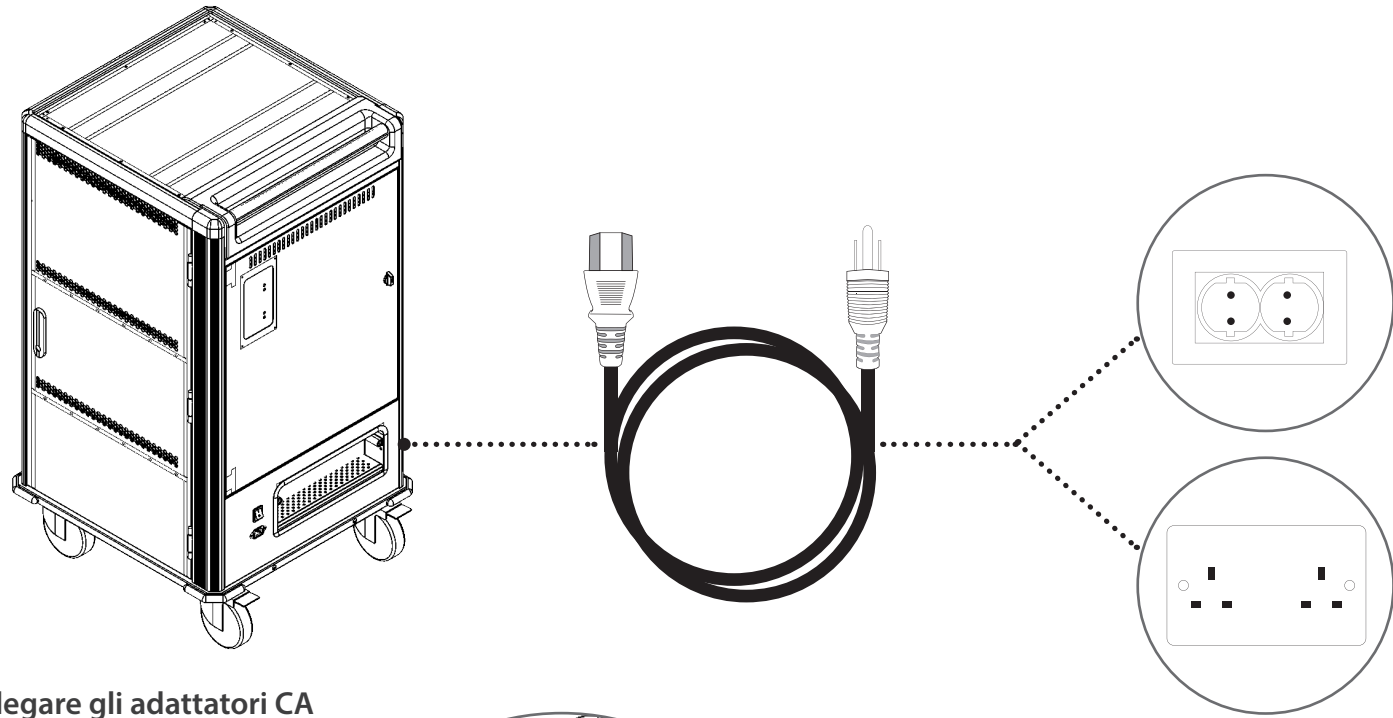

2. Collegare gli adattatori CA

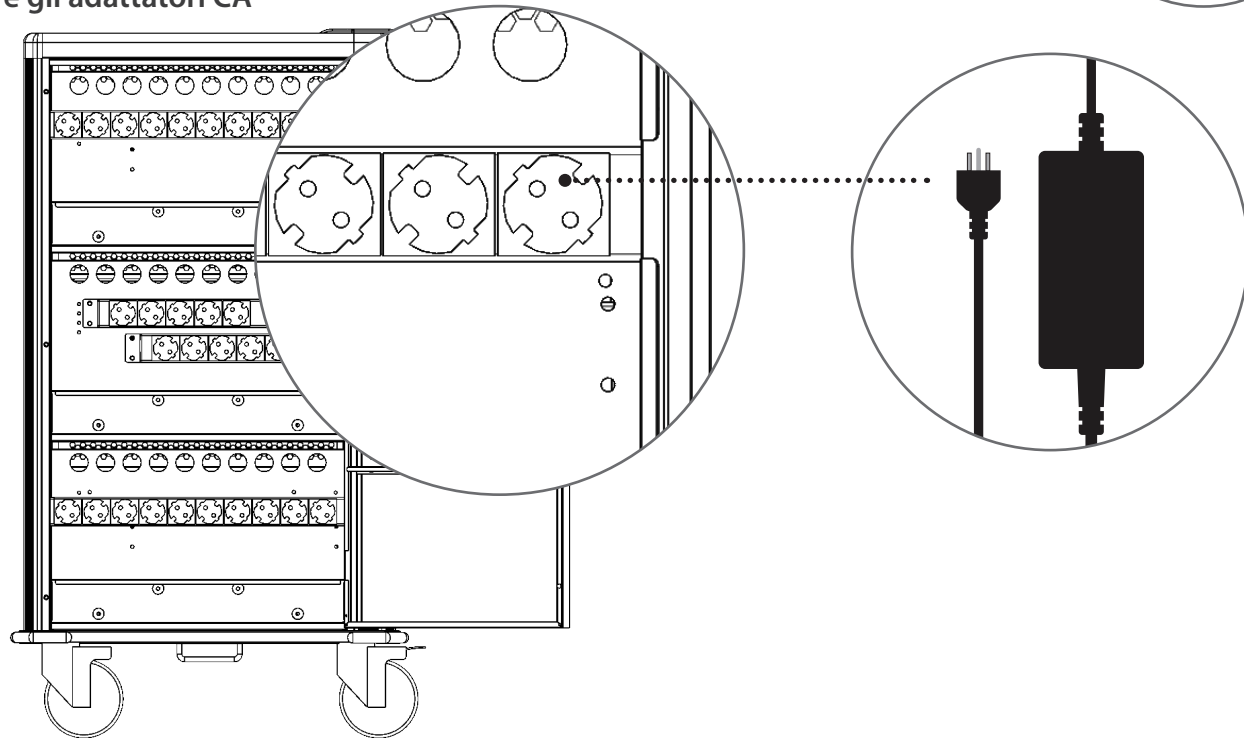

3. Posizionare gli adattatori nei porta alimentazione

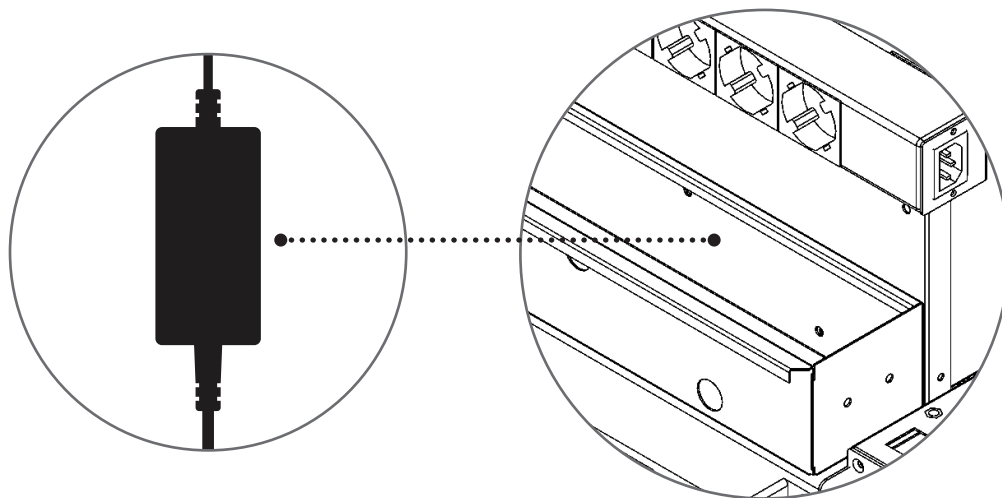

4. Far passare gli adattatori attraverso i fori passanti

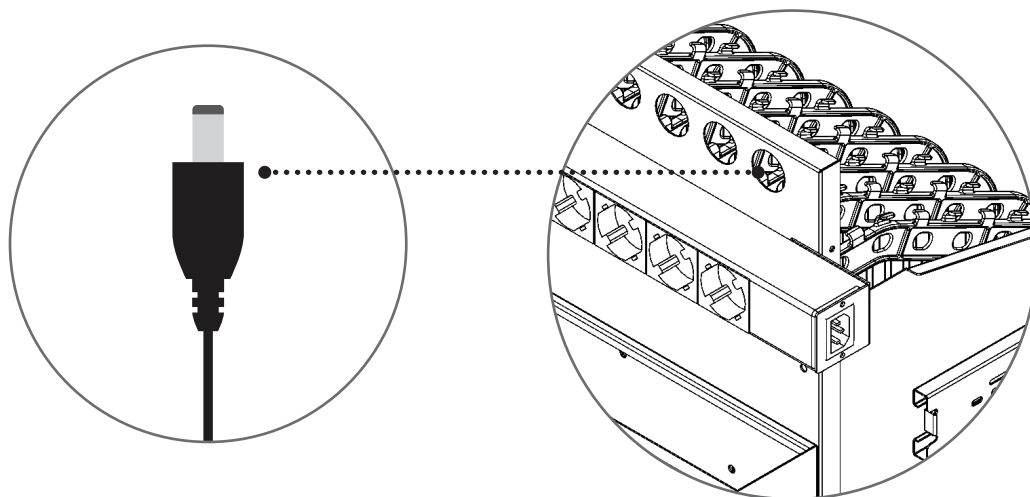

5. Collocare i cavi degli adattatori sui divisori portacavi

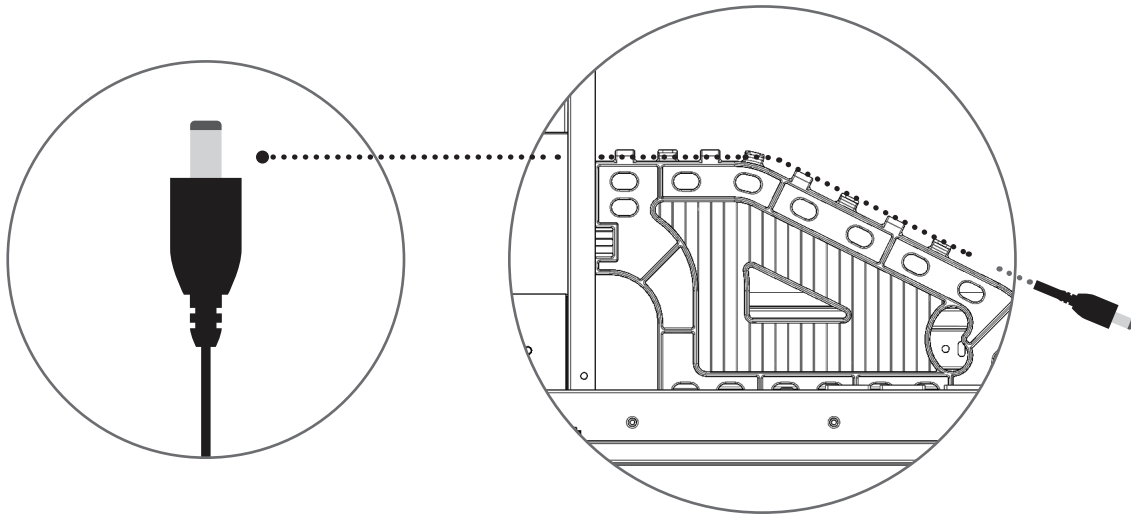

6. Posizionare i dispositivi nei divisori

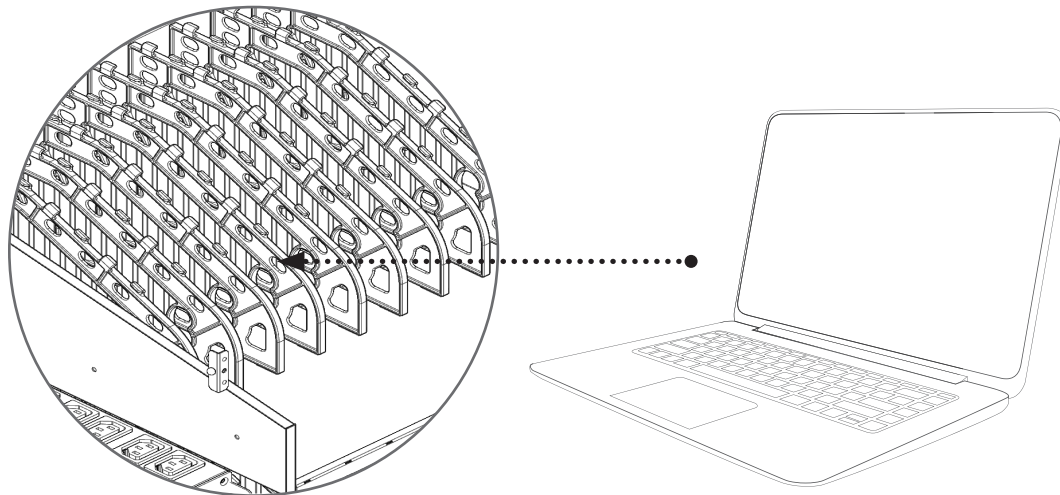

Sistema di carica

La ricarica di tutti i dispositivi contemporaneamente può sovraccaricare un circuito tipico. I carrelli di ricarica V7 sono dotati di un dispositivo di temporizzazione intelligente che commuta automaticamente l'alimentazione CA da una metà all'altra delle prese dei dispositivi per evitare il sovraccarico.

L'indicatore a LED posto all'esterno del carrello indica quale set è attualmente in carica.

Sistema di carica	Sensore intelligente
In che modo carica	Ricarica a ciclo tra 2 gruppi. Quando la corrente complessiva è inferiore a 14 Amp, inizia la carica completa
Spia LED	Blu (Acceso): In carica Spento: Non in carica



Durante la carica,
l'indicatore LED è blu

CHGCT30

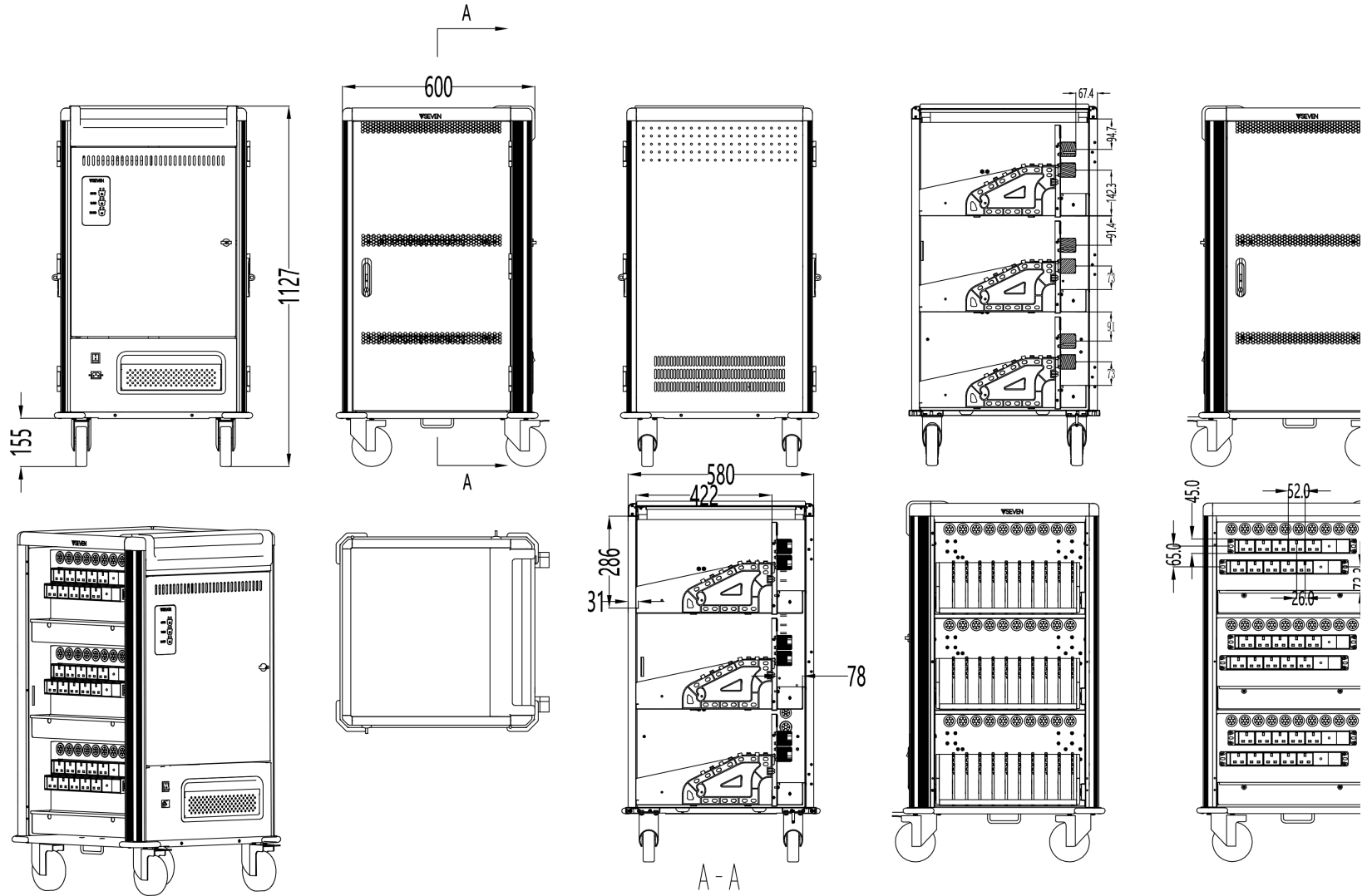

CHGCT36

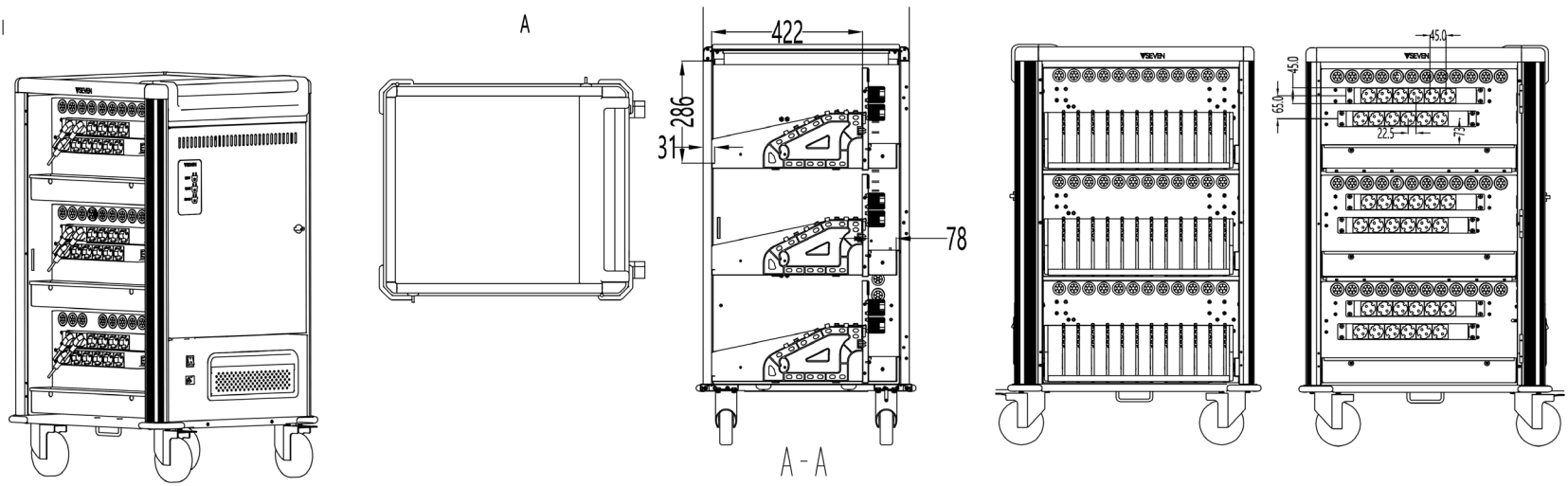
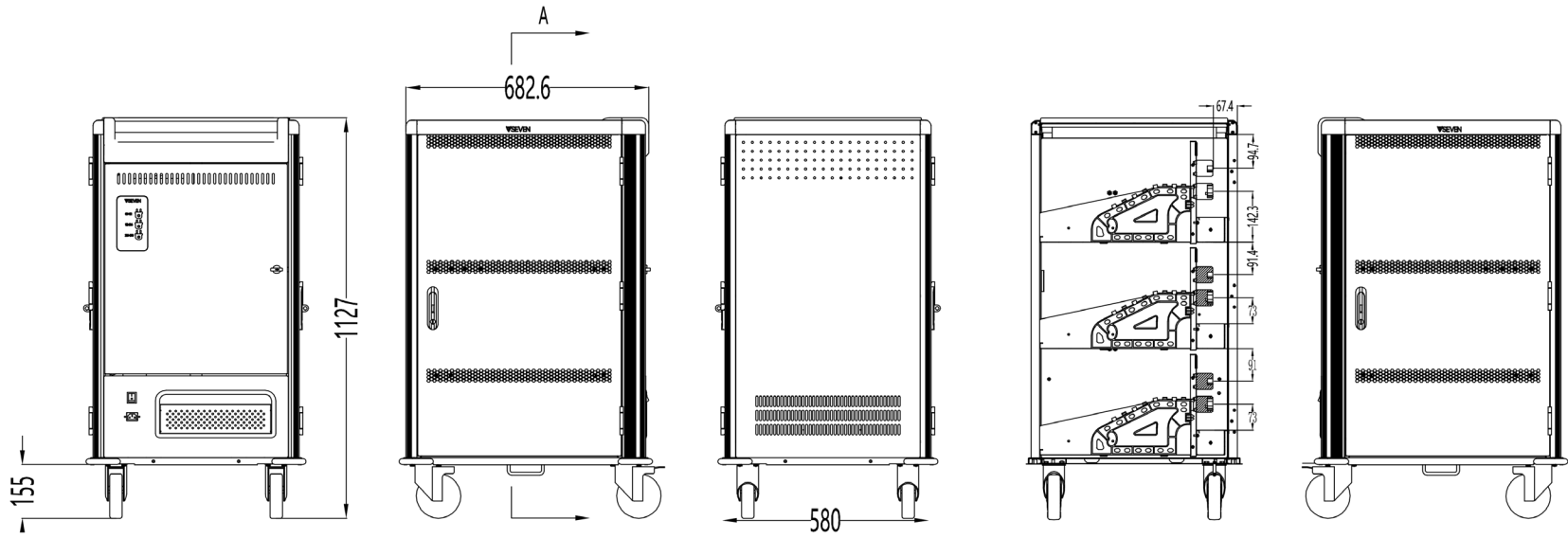

	CHGCT30	CHGCT36
Colore	Nero e grigio scuro	Nero e grigio scuro
Materiale	Acciaio laminato a freddo di alta qualità calibro 18	Acciaio laminato a freddo di alta qualità calibro 18
Spazi numerati per dispositivi	30	36
Organizzazione e praticità	Divisori flessibili per dispositivi con canali per cavi e fessure dei dispositivi numerate, fessure per adattatori di alimentazione numerati con gestione dei cavi, maniglie di spinta incassate	Flexible device dividers with cable channels and numbered device slots, numbered power adapter slots with cable management, recessed push handle
Garanzia	5 anni	5 anni
Contenuto della confezione	Carrello di ricarica, cavo di alimentazione da 1,83 m, manuale	Carrello di ricarica, cavo di alimentazione da 1,83 m, manuale
Tensione d'ingresso	230VAC, 15A, 60HZ	230VAC, 15A, 60HZ
Tensione di uscita	230VAC, 15A, 60HZ	230VAC, 15A, 60HZ
Sistema di carica	Intelligent Charging	Intelligent Charging
Dimensione ruote	5 in (12.7 cm)	5 in (12.7 cm)
Dimensioni del prodotto	23.62 x 22.82 x 44.37 in (599.94 x 579.62 x 1126.998 mm)	26.89 x 22.83 x 44.47 in (683 x 580 x 1127 mm)
Peso del prodotto	171.96 lbs (78 kg)	187.39 lbs (85 kg)
Dimensione della confezione	25.98 x 25.59 x 50.08 in ()	28.94 x 25.59 x 50.08 in (753 x 650 x 1272 mm)
Peso della confezione	205.03 lbs (93 kg)	218.26 lbs (99 kg)
Dimensioni fessure per dispositivi	16.61 x 1.38 x 11.25 in (422 x 35 x 286 mm)	16.61 x 1.38 x 11.25 in (422 x 35 x 286 mm)
Dimensioni fessura adattatore di alimentazione	3.07x 18.22 x 4.48 in (78 x 463 x 114mm)	3.07x 18.22 x 4.48 in (78 x 463 x 114mm)
Ambiente*	"Uso: da -10°C a 40°C Umidità: da 20% a 80% RH Storage: da -40°C a +60°C Umidità: da 20% a 90% RH"	"Uso: da -10°C a 40°C Umidità: da 20% a 80% RH Storage: da -40°C a +60°C Umidità: da 20% a 90% RH"

*Nota: dati validi solo per il carrello. Controllare le specifiche ambientali dei dispositivi stoccati sul carrello.

